



# 4.0 cu ft Electric Concrete Mixer

Operator's Manual

**MODEL NUMBER**  
YM0115

**SERIAL NUMBER**

**PURCHASE DATE**

Both model number and serial number may be found on the main label (see **Page 2, Figure 1**). You should record both of them in a safe place for future use.

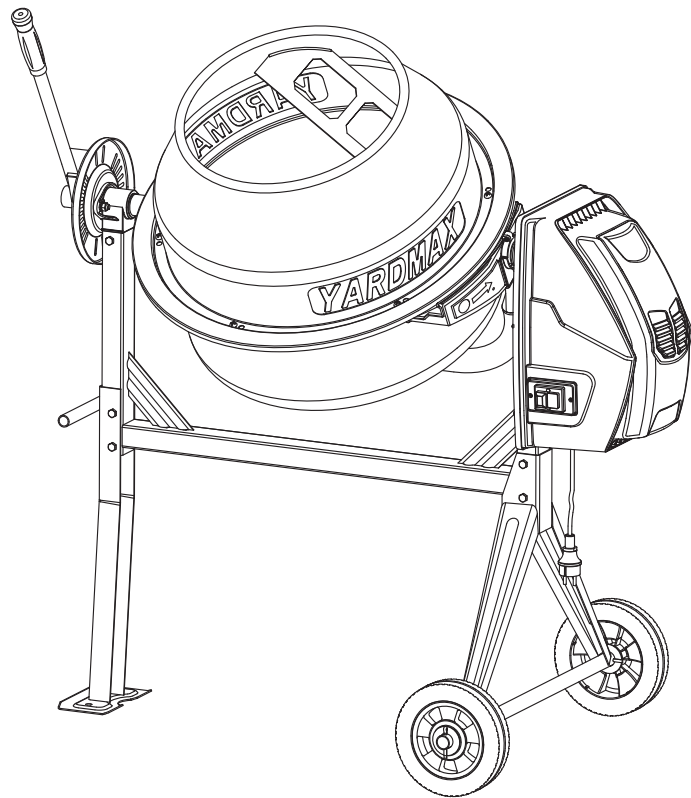

---

**FOR YOUR SAFETY**

*READ AND UNDERSTAND THE ENTIRE MANUAL BEFORE OPERATING MACHINE*

---

Your new YARDMAX™ electric concrete mixer offers quality construction, and is easy and safe to operate. With proper use and care, it is designed to give you many years of dependable service.

Prepare to experience the durability to take on any job – with the ease, portability, and convenience of clean, electric mixing!

### Discover the YARDMAX Advantage

At YARDMAX, we understand that land ownership definitely has its privileges, but it also comes with a great deal of responsibility. When duty calls and you need to respond, will you have what it takes to tame the great outdoors?

When looking for outdoor power equipment (OPE) to get the job done right, at the right price, YARDMAX delivers the perfect combination of performance and practicality. YARDMAX has a solution that's right for you.

### MAX Performance, MAX Value, MAX Support – that's YARDMAX

- ✓ Backed by decades of proven manufacturing expertise
- ✓ Enhanced design features are standard
- ✓ Engineered for the best user experience
- ✓ Quality metal parts are used instead of plastic
- ✓ A robust warranty supports all products
- ✓ Budget-friendly prices make it practical



*Up for the job? YARDMAX is.*

---

## TABLE OF CONTENTS

---

Introduction	1
Specifications	3
Symbols	3
Safety	4
Contents Supplied	6
Assembly	7
Know Your Machine	11

Operation	12
Maintenance	14
Wiring Diagram	15
Troubleshooting	15
Parts Diagram	16
Parts List	17



Carefully read through this entire operator's manual before using your new Concrete mixer. Pay attention to all cautions and warnings.

## ENVIRONMENTAL



Recycle unwanted materials instead of disposing of them as waste.

## MODEL AND SERIAL NUMBERS

For future reference, record both the model number (see **Figure 1, Illustration a**) and the serial number (see **Figure 1, Illustration b**), as well as date and place of purchase. Have this information available when ordering parts, optional accessories and when making technical or warranty inquiries.

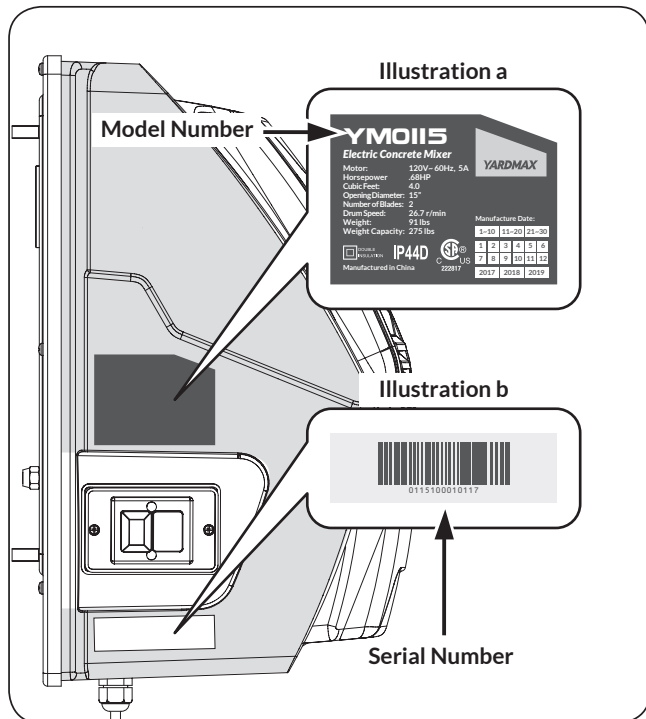

Figure 1

## DISCLAIMER

YARDMAX reserves the right to discontinue, change, and improve its products at any time without notice or obligation to the purchaser. The descriptions and specifications contained in this manual were in effect at printing. Equipment described within this manual may be optional. Some illustrations may not be applicable to your unit.

## SUPPORT

Have questions about your YARDMAX equipment? Call us at 844-YARDMAX, email us at support@yardmax.com, or contact us via your favorite social media site.

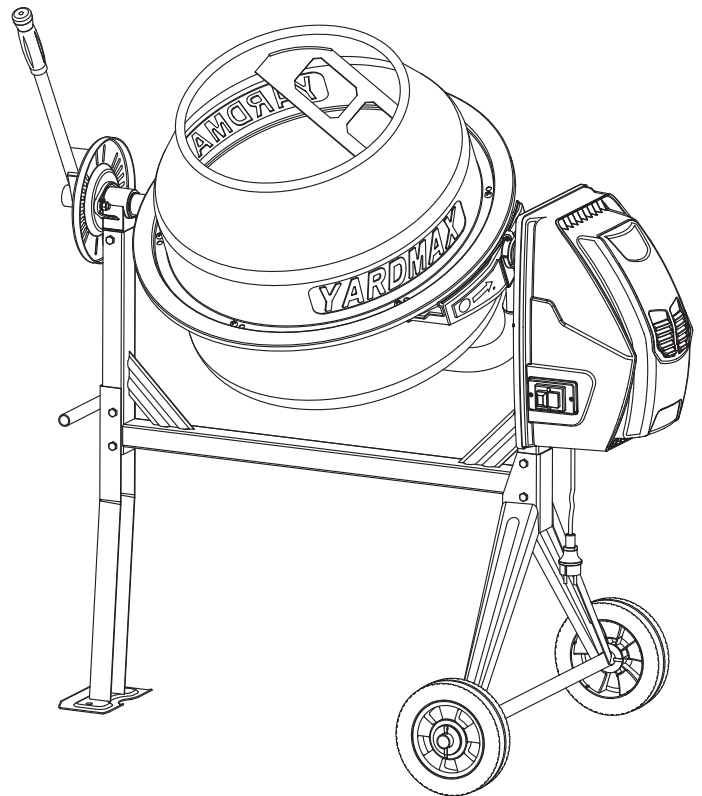

## SPECIFICATIONS

Model Number	YM0115
Cubic Feet	4.0
Motor	120V~ 60Hz, 500W
Horsepower	.68HP
IP45 Washdown	Yes
Drum Type	Steel
Weight Capacity	275 lbs
Number of Blades	2
Opening Diameter	15"
Product Weight	100 lbs

## SYMBOLS

The rating plate on your machine may show symbols. These represent important information about the product or instructions on its use.



Read these instructions carefully.



Wear eye protection.

Wear hearing protection.



Wear protective gloves.



Wear safety footwear.



Only use or operate the mixer on solid, flat, level ground that is capable to support the weight of the mixer and its load. To prevent the mixer from tipping over, only use or operate the mixer on solid, flat, level ground capable of supporting both the weight of the mixer and its contents.



Only use or operate the mixer on solid, flat, level ground capable of supporting both the weight of the mixer and its contents.



Do not attempt to move the mixer when it is loaded and/or in operation.



Check your mixer before turning it on. Keep guards in place and in working order.



Replace damaged, missing or failed parts before using it.



Keep hands out of the way of all moving parts.



Do not place any part of your body or any tool, like shovel in the drum during operation.



When operating, do not pass hands through the clearance between frame and support arm or the one between the drum and support arm.



Do not start the motor if the drum is fully loaded. Do not turn mixer off while full of concrete.



Take left over materials to an authorized collection point or follow the stipulations in the country where the mixer is used. Do not discharge into drains, soil or water.



Take left over materials to an authorized collection point or follow the stipulations in the country where the mixer is used. Do not discharge into drains, soil or water.



Keep children and bystanders off and away.



Disconnect the main plug prior to the repair, cleaning, and maintenance of the mixer!

## SAFETY

### KNOW YOUR CONCRETE MIXER

Read this manual and all labels to understand your YARDMAX concrete mixer and its limitations and potential hazards.

### DRUGS, ALCOHOL, AND MEDICATION

Do not operate your concrete mixer while under the influence of drugs, alcohol, or any medication that could affect your ability to use it properly.

### AVOID DANGEROUS CONDITIONS

Secure your concrete mixer on level ground. Keep your work area clean and well lighted. Cluttered areas may cause injuries. Do not use your concrete mixer in wet or damp areas or expose it to rain. Do not use it in areas where fumes from paint, solvents, or flammable liquids pose a potential hazard.

To prevent the mixer from tipping over, only use or operate the mixer on solid, flat, level ground capable of supporting the weight of both the mixer and its load. Do not attempt to move the mixer when it is loaded and/or in operation. This mixer is intended for the production of concrete, mortar and plaster. It is not suitable for the mixing of flammable or explosive substances. Do not use it in areas where fumes from paint, solvents or flammable liquids pose a potential hazard.

### INSPECT YOUR CONCRETE MIXER

Check your mixer before turning it on. Keep guards in place and in working order. Do not plug mixer with motor cover off. Check all bolts, nuts, and screws for tightness before each use, especially those securing guards and drive mechanisms. Vibration during mixing may cause these to loosen. Form a habit of checking to see that all the adjusting tools, shovels, hand trowels and other tools/equipments are removed from mixer area before turning it on. Replace damaged, missing or failed parts before using it. Warning labels carry important information. Replace any missing or damaged warning labels.

### DRESS PROPERLY

Do not wear loose clothing, gloves, or jewelry (rings, watches) that can be caught in moving parts. Wear protective, non-conductive gloves and non-skid footwear. Pull long hair back or wear a hat to prevent hair from getting caught in the machine.

### PROTECT YOUR EYES

Always wear safety glasses. Concrete mixers can throw foreign objects into the eyes, causing permanent eye damage. Every day glasses do not have impact-resistant lenses and should not replace safety glasses. Z87 rated glasses are recommended.

### PROTECT YOUR BODY

Always stand behind the concrete mixer and stay alert.

### KEEP VISITORS AND CHILDREN AWAY

Keep unauthorised persons away from the mixer. Do not allow children to handle or climb on or in the mixer.

### EXTENSION CORDS

Improper use of extension cords can cause the motor to overheat. Your extension cord should be no longer than 30 feet and a minimum of 12 gauge with a 3-prong grounded plug.

Avoid use of free and inadequately insulated connections. Connections must be made with protected material suitable for outdoor use. Make sure that any extension cord connections are dry and safe. Ensure that the extension cord is carefully laid out avoiding liquids, sharp edges and places where vehicles might run over it. Avoid allowing the extension cord to be trapped underneath the mixer. Unroll it fully or it will overheat and could catch fire.

### AVOID ELECTRICAL SHOCK

Do not plug or unplug the motor while standing in or around damp or wet ground. Do not use the mixer in wet or damp areas or expose it to rain. Prevent body contact with grounded surfaces: pipes, radiators, ranges, and refrigerator enclosures. Make sure your fingers do not touch the plug's metal prongs when plugging or unplugging the mixer.

Do not touch the electric wires inside the motor cover. For any service please contact YARDMAX or an authorized service center. Make sure your fingers do not touch the plug's metal prongs when plugging or unplugging the concrete mixer.



**WARNING!** Stay of clear of all moving parts!

### DON'T OVERREACH

Keep proper footing and balance at all times when loading or unloading the mixer. Never stand on mixer. Serious injury could occur if the mixer is tipped or if the moving parts are unintentionally contacted. Do not store anything above or near the mixer where anyone might stand on the mixer to reach them.

### AVOID INJURY FROM ACCIDENTS

Keep hands out of the way of all moving parts. Do not place any part of your body or any tool - such as a shovel - in the drum during operation. When operating, do not pass hands through the clearance between frame and support arm, or through the space between the drum and the support arm.

### PROTECT YOUR HANDS

Keep your hands away from all moving parts. Do not place any part of your body in the drum, or under the finger guard, at any time while the motor is on.

**DO NOT FORCE TOOL**

Do not use the concrete mixer for any other purpose than that for which it was intended. Do not start the motor if the drum is fully loaded. Do not turn the mixer off if it still contains concrete. The mixer is not to be towed.

**NEVER LEAVE MACHINE UNATTENDED**

Do not leave your concrete mixer until it has come to a complete stop.

**DISCONNECT POWER**

Unplug your concrete mixer when not in use and before making adjustments, changing parts, cleaning, or servicing. Consult the technical manual before servicing.

**PROTECT THE ENVIRONMENT**

Take left over materials to an authorized collection point or follow the stipulations in the country where the mixer is used. Do not discharge into drains, soil, or water.

**MAINTAIN YOUR CONCRETE MIXER WITH CARE**

Keep your concrete mixer and its parts clean.

**CHILDPROOF YOUR WORKSHOP**

Store your concrete mixer away from children and others not qualified to use it.

## CONTENTS SUPPLIED

Your YARDMAX concrete mixer comes partially assembled and contains the following:

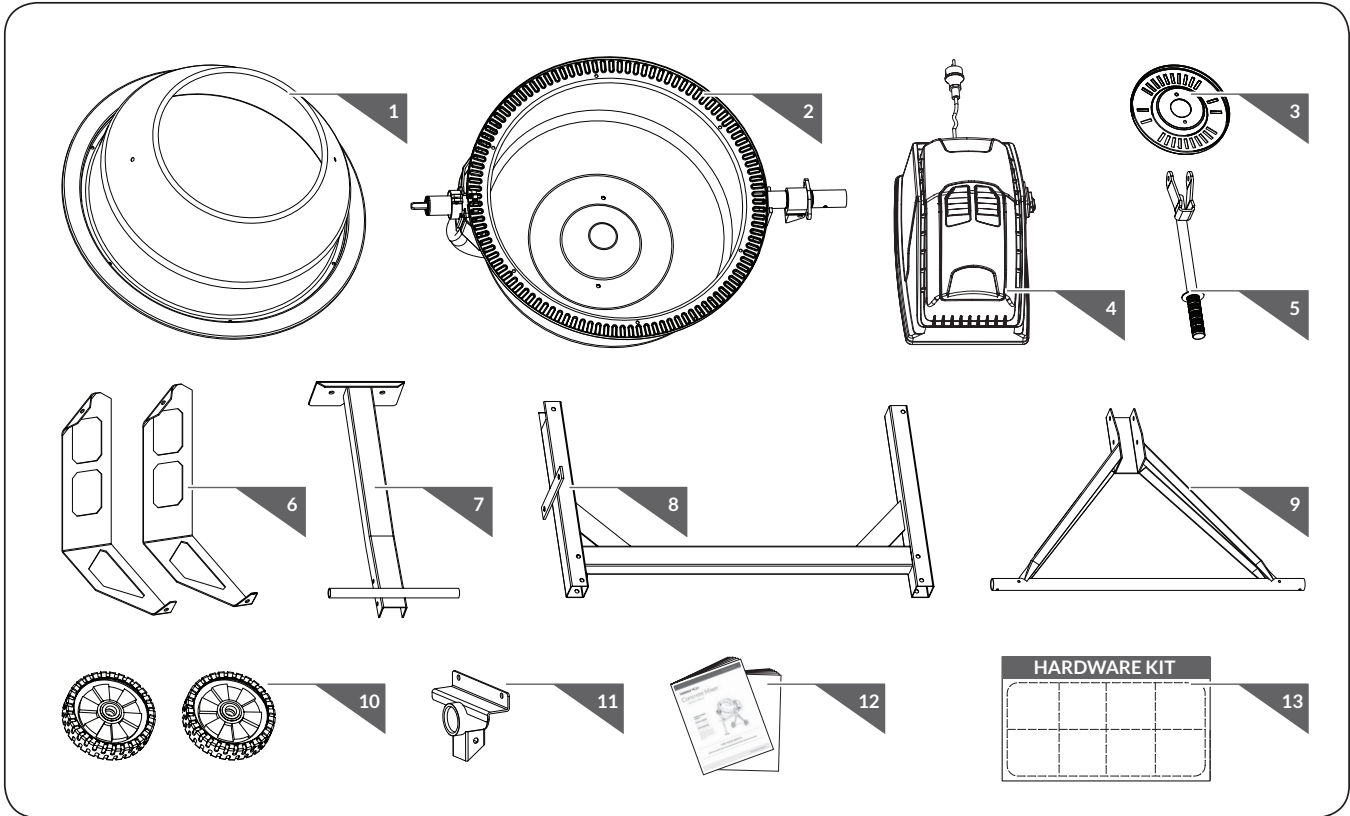

1. Upper Drum
2. Bottom Drum with Support Arm
3. Locking Plate
4. Motor Assembly
5. Tipping Bar
6. Mixing Blades (1 Pair)
7. Support Leg
8. Support Frame
9. Wheel Axle Bracket
10. Wheels (1 Pair)
11. Motor Support Bracket
12. Operator's Manual
13. Hardware Bag

		× 4	<b>1</b>
	M8 × 70	× 2	<b>2</b>
	M8 × 70	× 2	<b>3</b>

	M8 × 65	× 2	<b>4</b>
	Ø 42	× 1	
	M8 × 20	× 2	<b>5</b>
	M8 × 20	× 6	<b>6</b>
	M8 × 20	× 2	
	M8 × 25	× 2	<b>7</b>
	M10 × 65	× 1	<b>8</b>
		× 1	
	M8	× 4	<b>9</b>

TOUCH-UP PAINT			
	Orange	X 1	<b>10</b>
	Light Gray	X 1	

# ASSEMBLY

This concrete mixer is partially assembled at the factory. To assemble your machine follow the below instructions.



Assembly requires two persons (recommended).

## STAND

1. Insert a split pin into the inner hole in each stub axle (See **Figure 1a, Illustrations 1-4** for details). Then, place a flat washer onto the axle, followed by the wheel, and then another flat washer. Insert another split pin into the outside axle hole. Bend each of the side pins outward so they do not fall out.

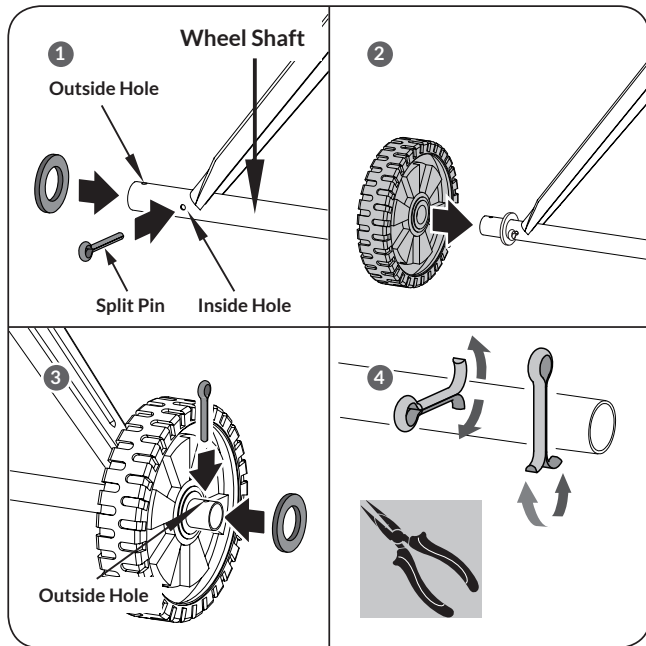

**Figure 1a**



× 4



2. With the frame lying on its side, attach the support legs. Align the 2 holes on the support leg with the frame holes as shown. (See **Figure 1b, Illustration 1**) Insert two M8×70 hex bolts through the holes, and secure with flat washers, lock washers, and nuts (See **Figure 1b, Illustration 2**).

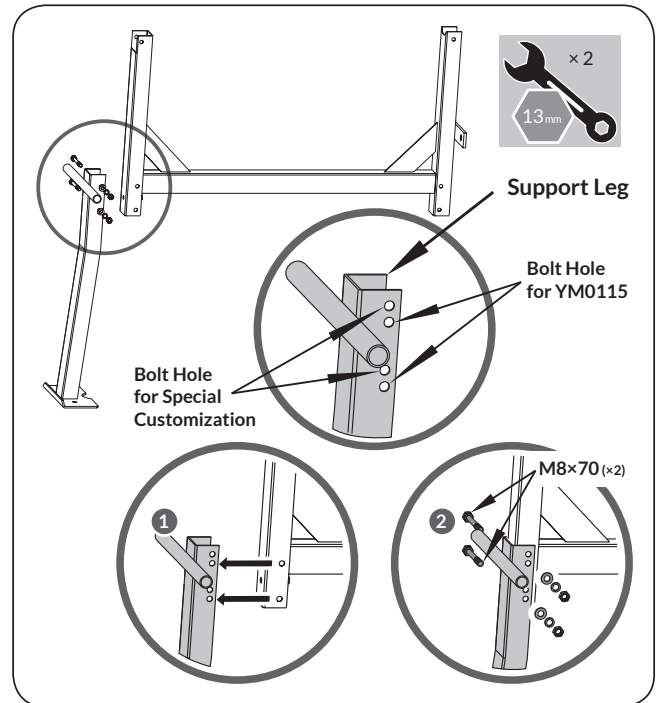

**Figure 1b**



M8 × 70

× 2



3. Turn the frame over and attach the axle bracket with wheels in the same manner. (See **Figure 1c, Illustrations 1-2**)

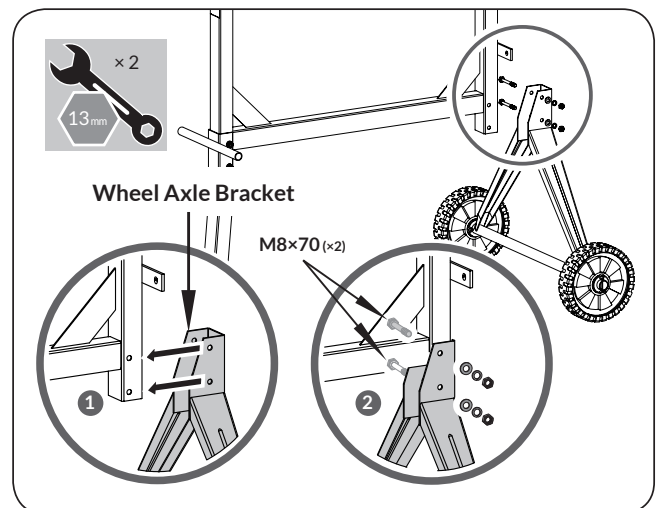

**Figure 1c**



M8 × 70

× 2



4. Make sure all bolts and nuts are tightened.



## BOTTOM DRUM

1. Slide the motor support bracket on the shaft. Hold it in place with Ø42 spiral ring. (See **Figure 2, illustration 1**)
2. Carefully place the bottom drum with support arm onto the side supports of the stand as shown. (See **Figure 2, Illustration 2**). The motor support bracket and support seat should slide into the side support channel on each side. The larger diameter shaft should be at the leg end of the stand.
3. On each side, line up the holes in the side support with those in the bearing block and insert a M8×65 hex bolt from one side, then a flat washer, lock washer and nut from the other side. Tighten with a wrench. (See **Figure 2, illustration 2-3**)

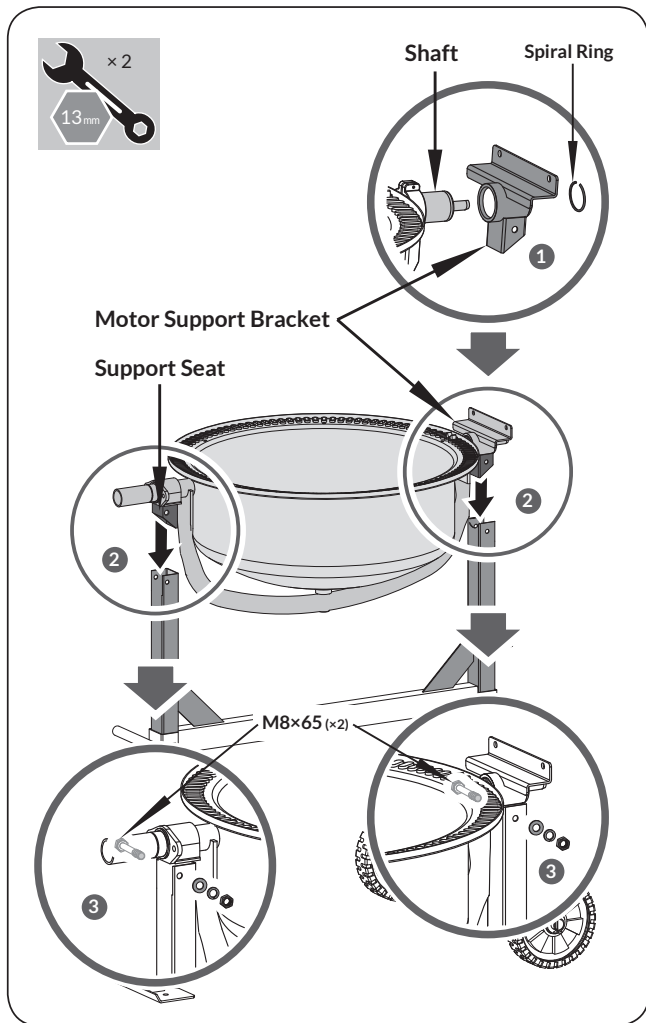



Figure 2

	M8 × 65	× 2	4
	Ø 42	× 1	

## MIXING BLADES

Mount the mixing blades inside the bottom drum loosely as shown (See **Figure 3, Illustration 1**) Two holes are provided at the base of the drum into which a M8×20 screw may be inserted from the outside. A leather washer, flat washer, lock washer and a nut should be threaded on loosely on the inside. The leather washer should be placed under the blade down against the drum. (See **Figure 3, Illustration 2**)

» Note the arrow labels on your mixer – one on the top drum and one on the bottom. If you have difficulty in correctly positioning the mixing blades, temporarily mount the upper drum on the top of the bottom drum, and rotate the top so the two arrows align.

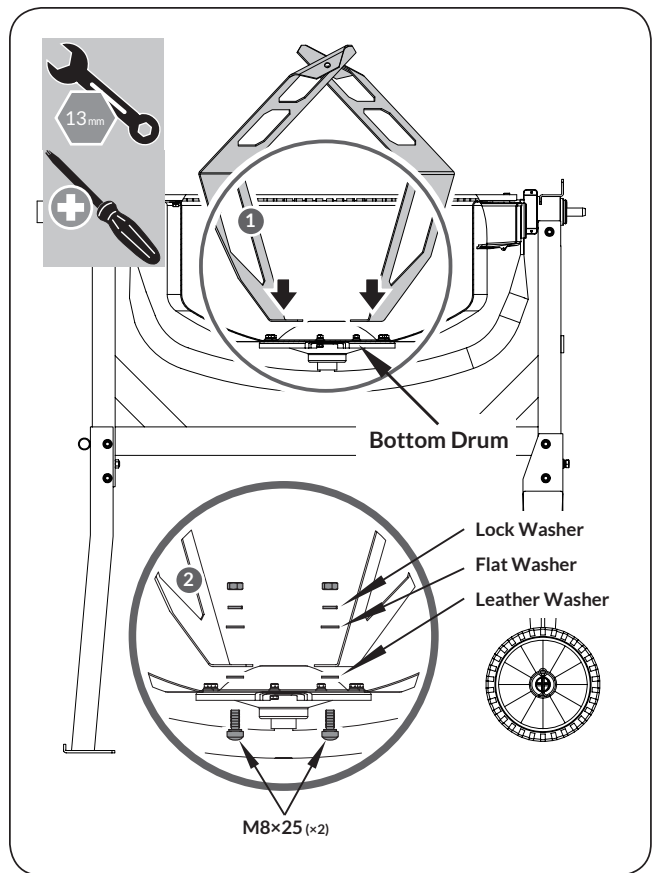

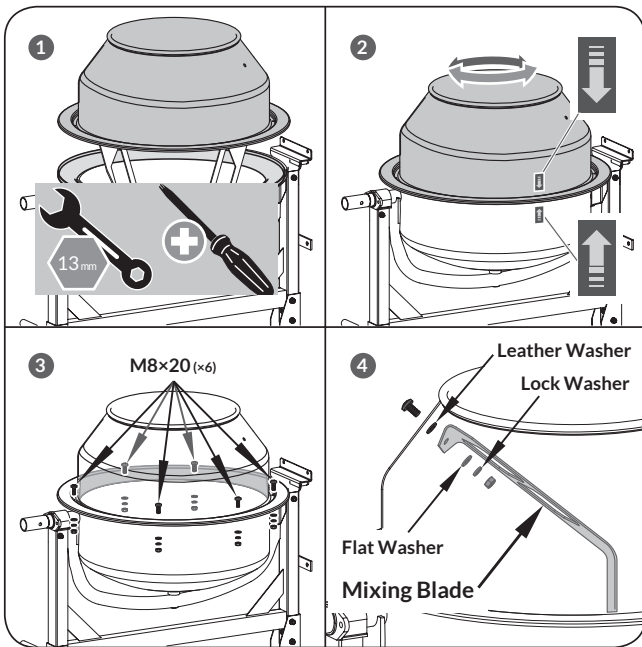

Figure 3

	M8 × 20	× 2	5
---	---------	-----	---

## UPPER DRUM

1. Place the upper drum onto the bottom drum by aligning both the mounting holes, and the labeled arrows. (See **Figure 4, Illustration 1 & 2**)
2. Insert a M8×20 cross headed screw into each mounting holes in the rim. Secure each screw from below with a flat washer, lock washer and nut. Make sure the tightening process is carried out progressively. (See **Figure 4, Illustration 3**)
3. Secure the mixing blades to the upper drum by inserting two M8×20 cross headed screws, from the outside through the holes in the drum.
4. A leather washer should be positioned inside between the drum and blade. Secure the mixing blade on the inside using a flat washer, spring washer and nut. (See **Figure 4, Illustration 4**)
5. Finally, ensure top and bottom mixing blade mountings are tight.

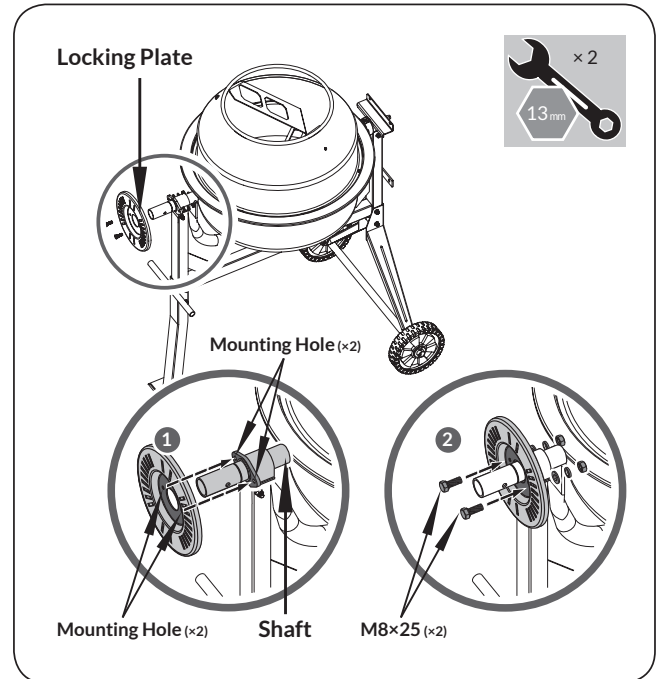

**Figure 4**

	M8 × 20	× 6	<b>6</b>
	M8 × 20	× 2	

## TIPPING BAR

1. Slide the locking plate over the large diameter shaft (at the “leg side” of the frame) with the rim facing inwards as shown. Insert two M8×25 bolts into the mounting holes, and secure each with a nut, lock washer and flat washer. (See **Figure 5a**)

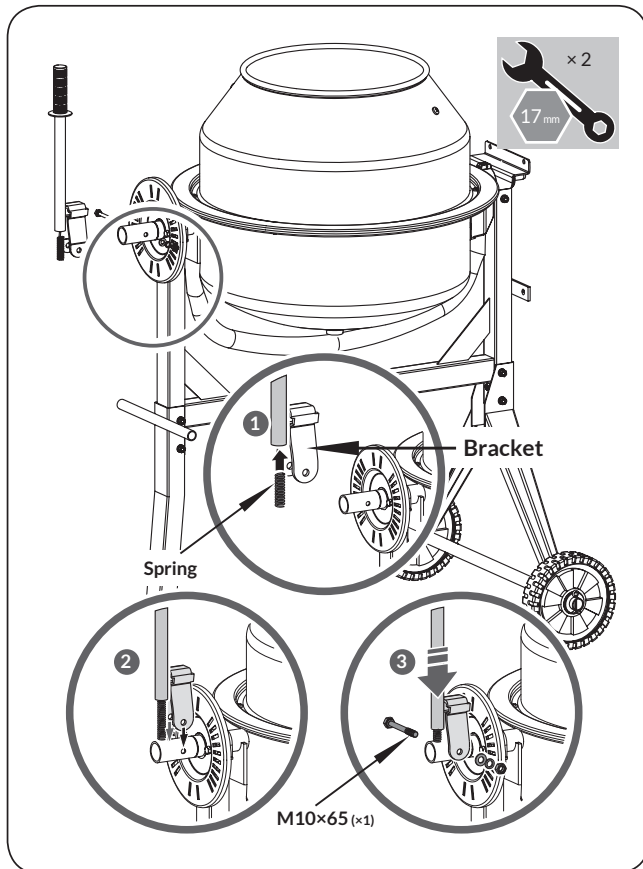

**Figure 5a**



	M8 × 25	× 2	<b>7</b>
--	---------	-----	----------

- Insert the spring into the bar pipe, hold the spring in place with a finger, and place the bar over the larger diameter shaft so the spring stays inside the bar pipe. (See **Figure 5b, Illustration 1**) Press down on bar pipe until the holes in the bracket line up with the hole drilled in the shaft. (See **Figure 5b, Illustration 2**) Insert a M10×65 hex bolt through the hole, place a flat washer on the bolt, and secure with nut. (See **Figure 5b, Illustration 3**) Secure the nut against the bracket, do not overtighten as this will prevent the bracket from pivoting on the bolt.

» The bar must be allowed to pivot about the bolt so that the lugs on the bracket can be engaged or disengaged from the slots in the locking plate.

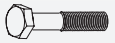
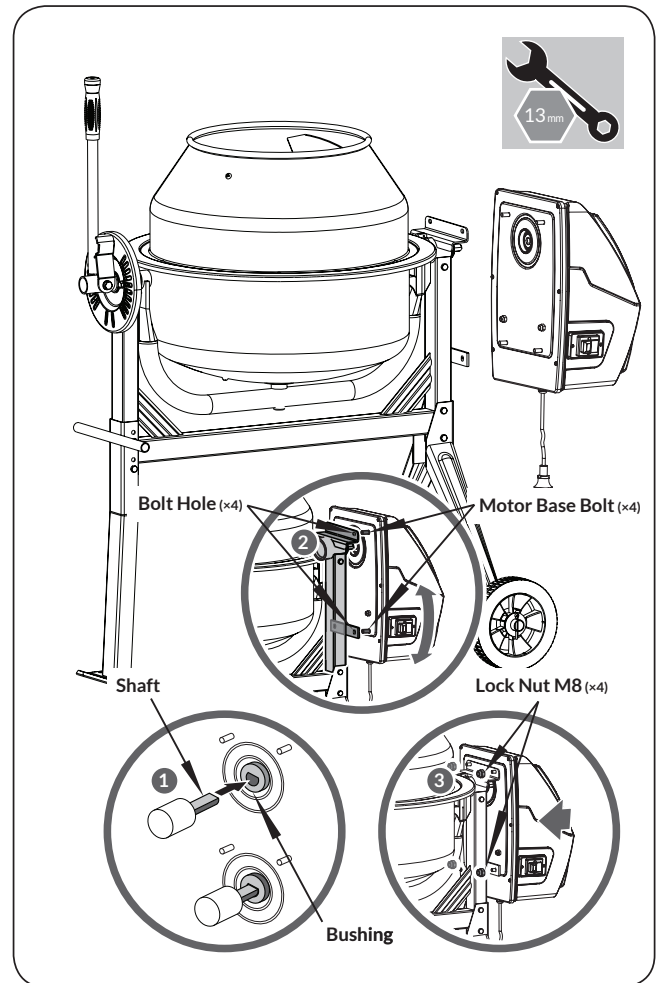

**Figure 5b**

	M10 × 65	× 1	8
		× 1	

## TRANSMISSION & MOTOR

Align the pinion shaft with the bushing sleeve in the transmission and slide into place. (See **Figure 6, Illustration 1**) Align the bolt holes in the frame bracket with the bolt studs in the motor case and slide into position. (See **Figure 6, Illustration 2**) Secure the motor case to the frame bracket using four M8 lock nuts. (See **Figure 6, Illustration 3**)



**Figure 6**

	M8	× 4	9
---	----	-----	---

---

# KNOW YOUR MACHINE

---

## FEATURES AND CONTROLS

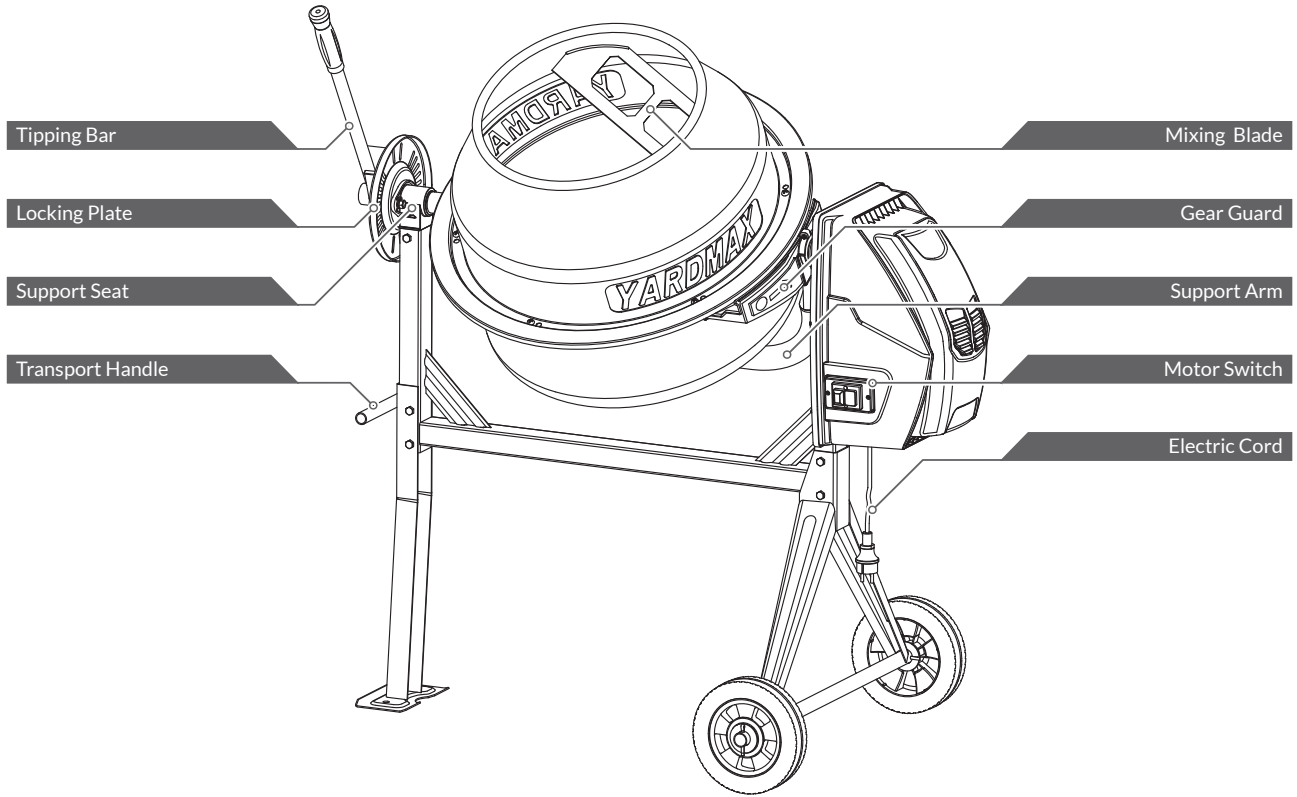

## OPERATION

### ELECTRICAL REQUIREMENTS

Confirm that you have a US Standard, 3 pin grounded, Type B, 15AMP (NEMA 5-15) outlet.

Check that the electric circuit is grounded, adequately protected, and that it corresponds with the power, voltage, and frequency of the motor.

### ELECTRICAL CONNECTION

This mixer is double insulated to Class II protection and IP44D rated. The insulation will only remain effective if the original insulating parts are used for repairs and the spaces between the original insulation are maintained.



*This mixer is double insulated to Class II protection and IP44D rated. Assembly and disassembly of the enclosure of electric control are critical to keep them remain effective. Only a qualified electrician is allowed to repair the enclosure of electric control.*



Double insulation (  ) eliminates the need for the three-pronged, grounded power cord and a grounded power supply system. Double-insulated devices can use either a two- or a three-pronged extension cord.



*Do not connect either cord to the earth pin.*

### STAKE ON LEVEL GROUND

To secure your YARDMAX concrete mixer during operation, use two longer bolts or stakes through the holes in the front leg of the mixer stand to hold the mixer in place. (See **Figure 7**) Due to varying ground surfaces, these are not included. Choose the right type of bolt or stake for your surface type or call us for a recommendation.

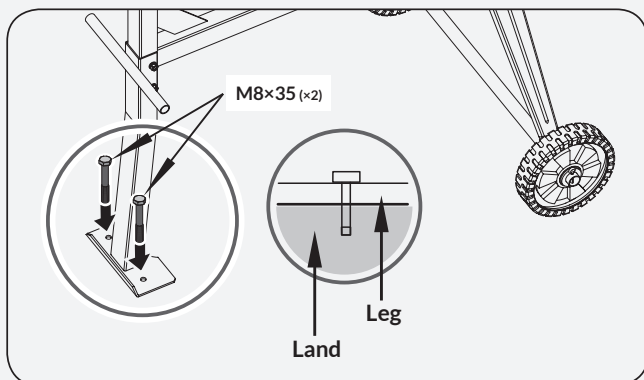

**Figure 7**

### DRUM TILTING

The spring-loaded tipping bar with locking lugs allows for tipping control of the drum (See **Figure 7**), and can be locked in the following positions (see **Figure 8b**): Loading/Mixing – mortar, Loading/Mixing – concrete, Discharging, and Storage.

The drum is locked into the desired position by the lugs on the self-locating tipping bar, which lock into the slots on the locking plate on the mixer frame. (See **Figure 8a**) To tilt the drum, pull the tipping bar slightly toward you (away from the frame) to disengage the locking lugs. This allows the tipping bar to turn the drum in the desired direction.

To lock the drum in position, slightly release the tipping bar (towards the mixer frame) when rotating the drum. The lugs will slide and then lock into the nearest position on the locking plate.

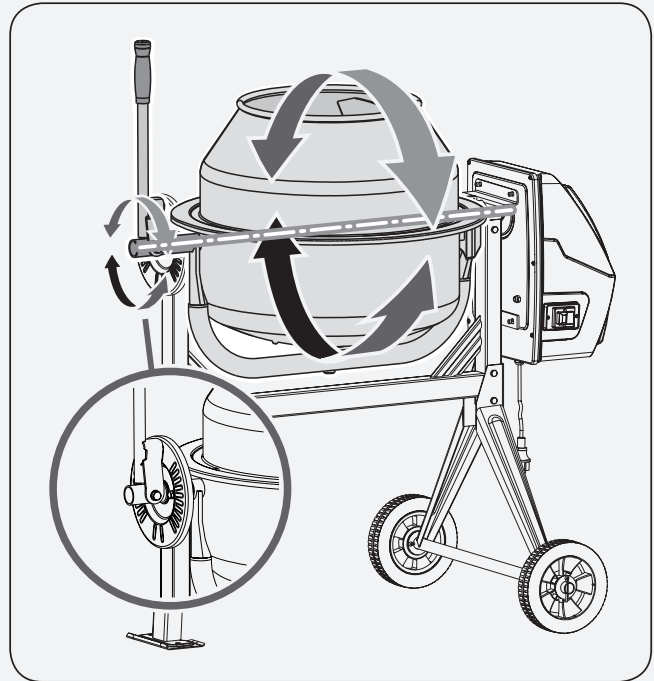

**Figure 8a**

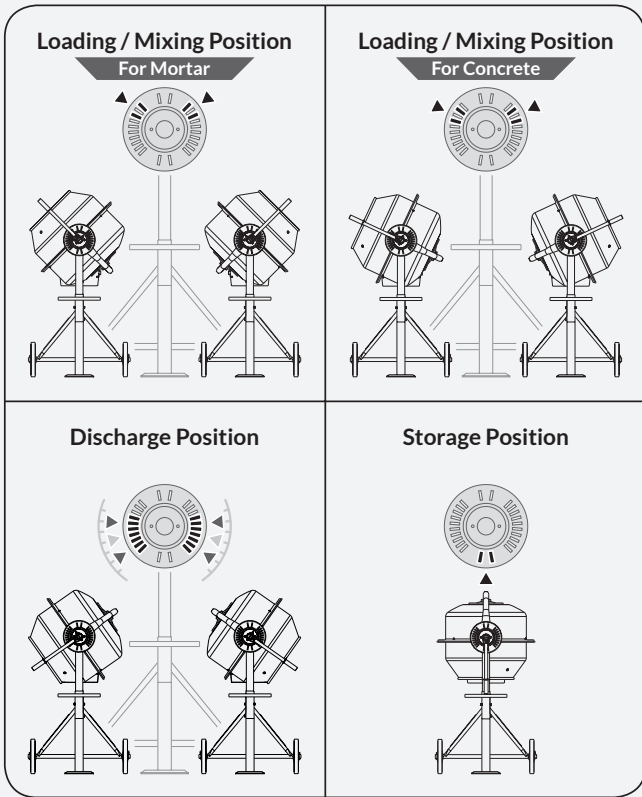

Figure 8b

## LOADING



Completely unwind the extension cord. Connect it to the concrete mixer first before plugging in power supply.



Always start the motor before you start loading the drum. The mixer blades should be turning before you start adding the contents.



To avoid concrete or mortar sticking to the insides of the mixer drum, slowly pour material into the mixer steadily over the rim.



A built-in thermal protector is installed in the motor to prevent overheating, and will cool automatically as the motor cools.

For best results, always load the mixer in the following order:

1. Add the required amount of gravel into the drum.
2. Add the required amount of cement into the drum.
3. Add the required amount of sand into the drum.
4. Pour the required amount of water into the drum.

## EMPTYING



Do not turn the mixer off (stop rotating arms) if you have content inside the bin. Always empty the drum completely with the mixer arms rotating.

## CLEANING



Never put hands or limbs inside the drum while the mixer arms are rotating.

Thoroughly clean the mixer at the end of each day's operation. Keep your mixer clean. The slightest trace of material left in the drum will harden and accumulate more each time you use it until the machine no longer will operate. Dried cement should be scraped out of the drum. Do not throw bricks into mixer drum to clean it out. Do not beat on the drum with a shovel, a hammer or other tools to break up accumulations of dried cement mix, as damage to the mixer may result. The drum may be scoured for approximately 2 minutes, using 1" gravel and water mixture. Then discharge the gravel/water mixture and hose down the drum assembly inside and out. The IP44D protection class construction of the concrete mixer enables you to hose down the drum assembly safely.



Do not pour or spray water directly over the motor cover, especially the openings in it.



Wipe off any external material on the motor cover. Do not use petrol, turpentine, lacquer or paint thinner, dry cleaning fluids or similar products. The use of chemical products or solvents may affect the properties of the cover which was made of high density polyethylene PET.

## MAINTENANCE



Ensure the extension cord is always unplugged before the motor cover is removed.

The drive belt maintains a constant, even tension provided by the spring-loaded jockey. No adjustment is needed other than an occasional touch of grease on the spindle.

The bearings are sealed for life.



The wiring diagram and parts schematic in this manual are for reference purposes only. Neither the manufacturer nor distributor makes any representation or warranty of any kind to the buyer stating that he or she is qualified to make any repairs to the product, or that he or she is qualified to replace any parts of the product. Only qualified technicians should repair the mixer. Any maintenance and repairs to any of the electric components must be performed by a qualified electrician.



Parts in a circle should only be fitted by a qualified electrician.

### REPLACING THE BELT

1. Remove the motor. (see **Figure 9a**)

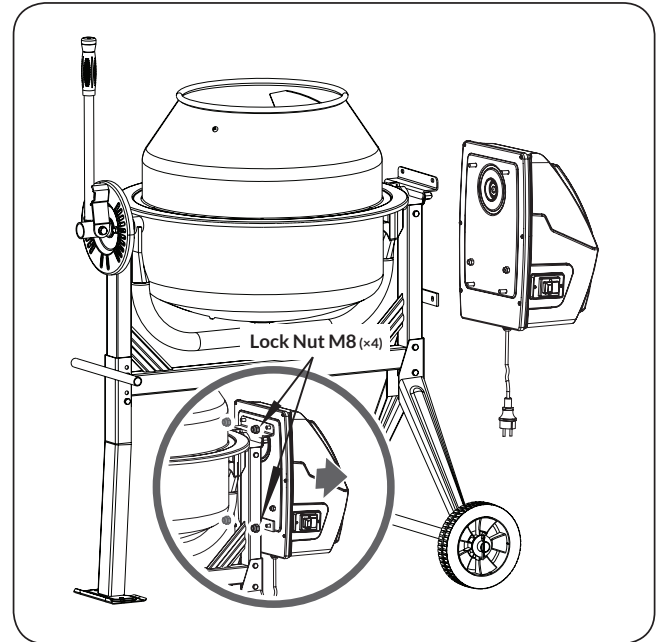

**Figure 9a**

2. Remove the motor cover. (see **Figure 9b, illustration 1**)
3. Turn the idle pulley and pull out the belt. (see **Figure 9b, illustration 2**)
4. Assemble the new belt and reattach the cover and motor assembly.

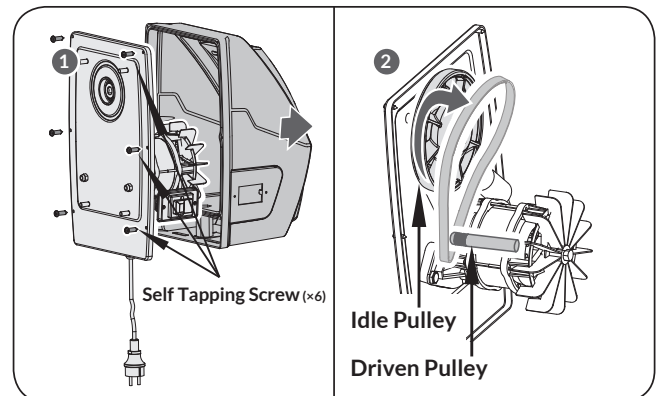

**Figure 9b**

## WIRING DIAGRAM

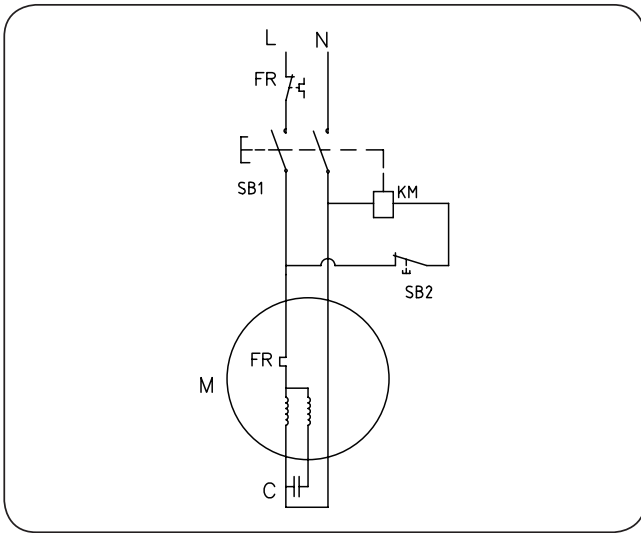

## TROUBLESHOOTING

Problem	Cause	Remedy
Motor stops working	Thermal protector works	Stop working for a while until motor cools
Drum fails to rotate	<ol style="list-style-type: none"> <li>1. Belt has broken</li> <li>2. Motor stops working due to overheat</li> </ol>	<ol style="list-style-type: none"> <li>1. Replace the new belt</li> <li>2. Stop working for a while until motor cools</li> </ol>



# PARTS DIAGRAM

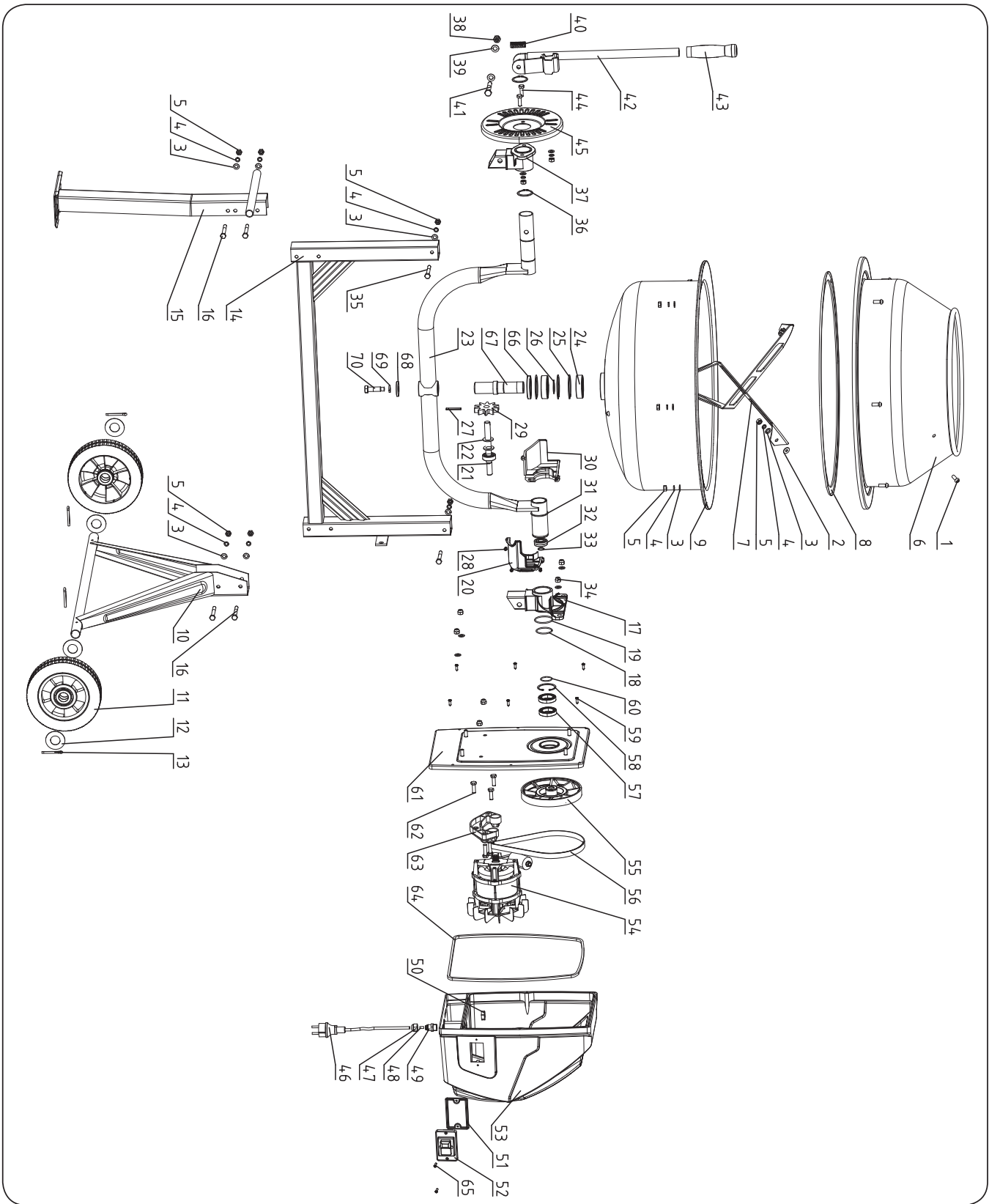

## PARTS LIST

No.	Description	QTY.
1	Cross Headed Screw M8×20	10
2	Waterproof Washer	4
3	Flat Washer 8	22
4	Spring Washer 8	18
5	Nut M8	18
6	Upper Drum	1
7	Mixing Blade	2
8	Rubber Gasket	1
9	Bottom Drum	1
10	Wheel Axle Bracket	1
11	Wheel	2
12	Flat Washer 27	4
13	cotter pin 5×40	4
14	Support Frame	1
15	Support Leg	1
16	Bolt M8×70	4
17	Motor Support Bracket	1
18	Circlip 42	1
19	O-ring	1
20	Gear Guard - Long	1
21	Drive Shaft	1
22	sleeve pipe	2
23	Cradle	1
24	Bearing 6206	2
25	Circlip 62	3
26	Circlip 30	1
27	Elastic pin 5×40	1
28	Self Tapping Screw ST4.2×13	3
29	Drive pinion	1
30	Gear Guard - Short	1
31	Circlip 42	1
32	Bearing 6202	2
33	Circlip 15	1
34	Lock Nut M8	4
35	Bolt M8×65	2

No.	Description	QTY.
36	Circlip 38	2
37	Support Seat	1
38	Lock Nut M10	1
39	Flat Washer 10	2
40	Spring	1
41	Hex.head bolt M10×65	1
42	Tipping Bar	1
43	Handle Grip	1
44	Bolt M8×25	5
45	Locking Plate	1
46	Electric Cord	1
47	Strain Relief Nut	1
48	Strain Relief Rubber	1
49	Strain Relief Bolt	1
50	Strain Relief Nut	1
51	Switch Gasket	1
52	Switch	1
53	Motor Cover	1
54	Motor	1
55	Idle Pulley	1
56	Belt	1
57	Bearing 6906	2
58	Snap Washer - Hole 47	1
59	Self Tapping Screw ST4.2×16	6
60	Circlip 30	1
61	End Plate	1
62	Bolt M8×25	3
63	Motor Mount Bracket, End Plate	1
64	Gasket	1
65	Self Tapping Screw ST3.5×16	2
66	Oil seal 62×35×8	1
67	Fixed Shaft	1
68	Washer	1
69	Spring Washer 12	1
70	Bolt M12×35	1



*Tame the Great Outdoors™*

