

**ITEM # PC3000**  
**3000 LB PLATE COMPACTOR**

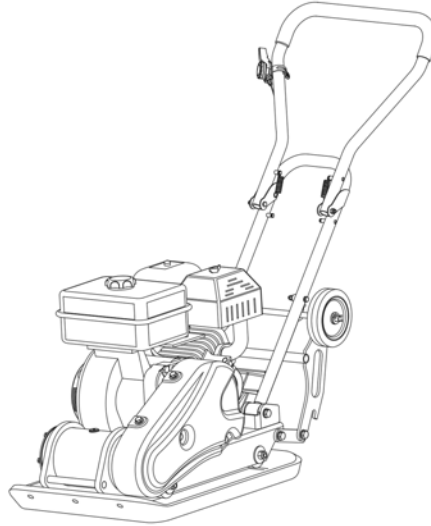

**READ ALL INSTRUCTIONS AND WARNINGS BEFORE USING THIS PRODUCT.**

This manual provides important information on proper operation & maintenance. Every effort has been made to ensure the accuracy of this manual. These instructions are not meant to cover every possible condition and situation that may occur. We reserve the right to change this product at any time without prior notice.

**IF THERE IS ANY QUESTION ABOUT A CONDITION BEING SAFE OR UNSAFE,  
DO NOT OPERATE THIS PRODUCT!**

**HAVE QUESTIONS OR PROBLEMS? CONTACT CUSTOMER SERVICE**

If you experience a problem or need parts for this product, visit our website <http://www.buffalotools.com> or call our customer help line at **1-866-460-9436, Monday-Friday, 8 AM - 4 PM Central Time**. A copy of the sales receipt is required.

**FOR CONSUMER USE ONLY – NOT FOR PROFESSIONAL USE.**

**KEEP THIS MANUAL, SALES RECEIPT & APPLICABLE WARRANTY FOR FUTURE REFERENCE.**

## FEATURES:

- Gasoline Engine 196cc
- Recoil Start
- 6.5 HP Engine
- Low Oil Shutdown
- Noise Level: 104 dB @ 0% Load
- Oil Capacity: 20 ounces
- Fuel Capacity: 1 gallon
- Centrifugal Force: 3000 lbs
- Compaction Depth: 11.8"
- Plate size: 21.25" x 16.5"
- Travel Speed (ft./min.): 0-50
- Speed: 5,500 VPM
- Includes Folding Mobility Kit
- EPA Approved
- This unit is not for use with gasoline/ ethanol blends with over 15% ethanol. Do not use E85 fuel.
- High Altitude Use: This unit is not recommended for high altitude use above 3,000 feet
- If you are using this unit above sea level, it may not function properly because of air flow getting through the carburetor.

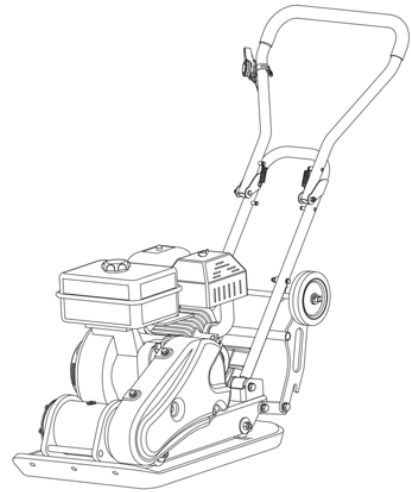

## 2 YEAR LIMITED EMISSION-RELATED WARRANTY

THIS ENGINE MEETS U.S. EPA EMISSION STANDARDS UNDER 40 CFR 1054.625 .The emission-related limited warranty is valid for two (2) years. Keep the purchase receipt and mail in the product registration card for proof of purchase. Buffalo Corp limits emission-related warranty repairs to authorized service centers for owners located within 100 miles of an authorized service center. For owners located more than 100 miles from an authorized service center, Buffalo Corp will, in its sole discretion, either pay for shipping costs to and from an authorized service center, provide for a service technician to come to the owner to make the warranty repair, or pay for the repair to be made at a local non-authorized service center. The provisions of this paragraph apply only for the contiguous states, excluding the states with high-altitude areas identified in 40 CFR part 1068, Appendix III.

To exercise this warranty, DO NOT RETURN TO RETAILER. Instead, call Customer Service toll free at 1-866-460-9436 (email address [info@buffalotools.com](mailto:info@buffalotools.com)) and you will be instructed on where to take the engine for warranty service. Take the unit and proof of purchase (your receipt) to the repair facility recommended by the Customer Service Representative. The warranty does not extend to units damaged or affected by fuel contamination, accidents, neglect, misuse, unauthorized alterations, use in an application for which the product was not designed and any other modifications or abuse.

## 1 YEAR LIMITED WARRANTY (30 Day Limited Warranty for Commercial and Rental Purpose)

Units are warranted to be free from defects in materials and workmanship for a period of 1 YEAR from date of original purchase. Buffalo Corp. is not liable for any indirect, incidental or consequential damages from the sale or use of this product. Any implied warranties are limited to 1 YEAR as stated, or as otherwise stated, in this written limited warranty. Some states do not allow the exclusion or limitation of incidental or consequential damages. Some states do not allow limitation on the length of an implied warranty. Buffalo Corp will repair or replace, at its discretion, any part that is proven to be defective in materials or workmanship under normal use during the 1 YEAR warranty period. Warranty repairs or replacements will be made without charge for parts or labor. Parts replaced during warranty repairs will be considered as part of the original product and will have the same warranty period as the original product. This warranty gives you specific legal rights, and you may have other rights that vary state to state.

## Notice Regarding Emissions:

Engines certified to comply with U.S. EPA emission regulations for SORE (Small Off Road Equipment) are certified to operate on regular unleaded gasoline and may include the following emission control systems: Three-Way Catalyst (TWC) (if equipped), and Engine Modifications (EM).

## Legal Requirements:

Federal and/or State Occupational Safety and Health Administration (OSHA) regulations, local codes, and/or ordinances may apply to the intended use of this unit. Consult a qualified electrician, electrical inspector, and/or the local agency having jurisdiction. Some areas require units to be registered with local utility companies. Additional regulations may apply if this unit will be used at a construction site.

## IMPORTANT SAFETY INSTRUCTIONS

# STOP!

Before using this unit and if you have any questions regarding the hazard and safety notices listed in this manual and/or on this unit, call 1-866-460-9436, Monday - Friday, 8 AM - 4 PM Central Time.

### **DANGER**

**Carbon Monoxide Gas:** When in operation, the exhaust from this engine contains poisonous carbon monoxide gas. Carbon monoxide gas is both odorless and colorless AND may be present even if you do not see or smell gas. Breathing this poison gas can lead to headaches, dizziness, drowsiness, loss of consciousness and eventually death.

### **WARNING**

**WARNING:** USE THIS UNIT ONLY OUTDOORS IN NON-CONFINED AREAS.

- Keep at least several feet of clearance on all sides to allow proper ventilation for this unit.

### **WARNING**

**Flammable Gasoline:** This engine may emit highly flammable and explosive gasoline vapors, which can cause severe burns or even death. A nearby open flame can lead to an explosion even if not directly in contact with gasoline.

- Do not operate this unit near open flame. Do not smoke near this unit.

**Gasoline is highly flammable and explosive. Handling fuel can result in serious injury or burns.**

- Always shut down this unit before refueling. Refuel in a well-ventilated area. Keep heat, sparks and flame away while refueling and away from the location where gasoline is stored. Never refuel indoors where gasoline fumes may reach flames and/or sparks.
- Allow this unit to cool for at least 2 minutes before removing the fuel tank cap. Loosen the cap slowly to relieve pressure in the fuel tank. Avoid spilling fuel.
- Do not fill the fuel tank above the upper limit line. Gasoline may expand during operation. Do not fill to the top of the tank.
- Always check for spilled gasoline and immediately wipe it up before starting this unit.
- Empty the fuel tank before storing or transporting this unit.
- Always handle fuel outdoors.
- Before transporting, turn the fuel valve to the "OFF" position and disconnect the spark plug.

### **DANGER**

**High Temperatures:** This unit produces heat when in operation. Temperatures near the exhaust can exceed 150 Degrees Fahrenheit (65 Degrees Celsius).

- Do not touch hot surfaces. Observe all warning placards on this unit denoting hot surfaces.
- Allow this unit to cool for several minutes after use before touching the engine, muffler or other areas that are hot during operation and before storing indoors.
- Hot exhaust may ignite some materials. Keep flammable materials away from this unit.
- Keep at least several feet of clearance on all sides of this unit during operation. Do not enclose this unit in any structure.

### **CAUTION**

**Usage:** Prolonged exposure to high noise levels can be hazardous to hearing. Always wear ANSI-approved hearing protection when operating or working around the unit when it is running.

### **CAUTION**

**Usage:** Misuse of this compactor can damage it or shorten its life. Use this compactor only for its intended purpose.

- Operate this compactor only on a dry, level surface. Do not secure the unit with a chain or rope, which would prevent it from being moved in an emergency.

# PACKAGE CONTENTS

The following items are supplied with this Unit. Verify that all items are included.

# STOP!

If there are missing items, call 1-866-460-9436, Monday - Friday, 8 AM - 4 PM Central Time for customer service.

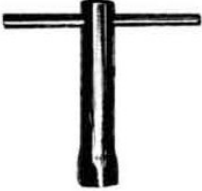
Item List:	
	Spark plug wrench

# ASSEMBLY COMPONENTS

Observe the locations of the various components and controls of this unit.

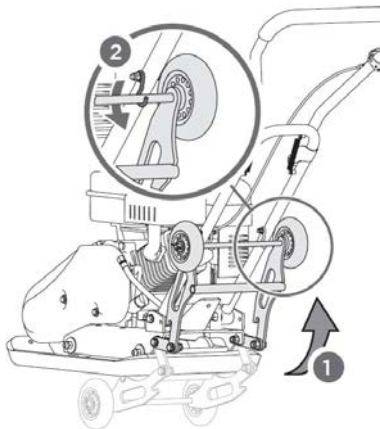
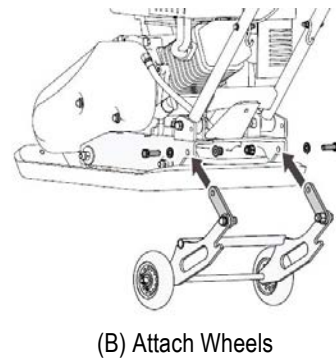
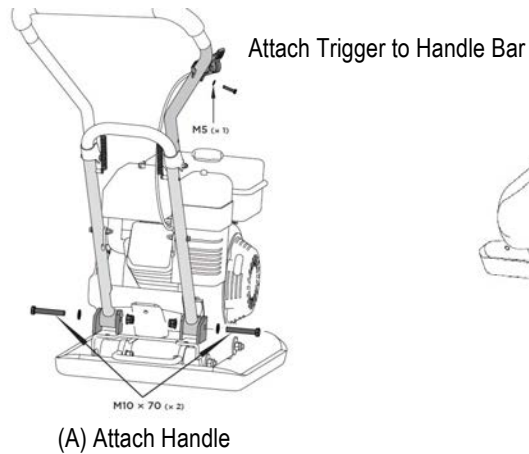
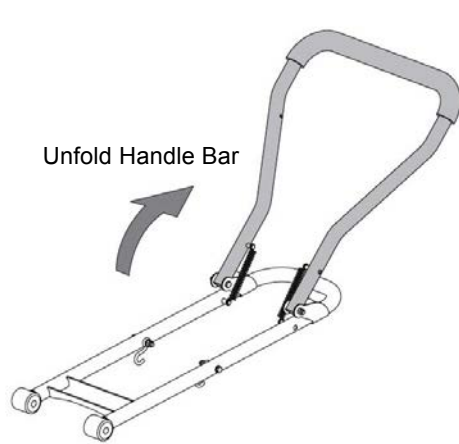

Before compacting, fold up the wheel kit as shown.

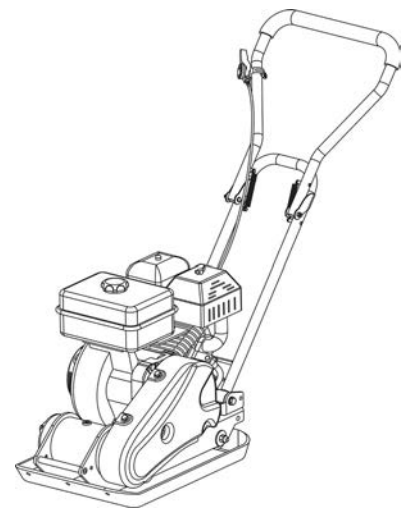

# PREPARING THE UNIT FOR USE

## Using this Unit for the First-Time

# STOP!

# CAUTION

The following section describes the required steps for preparing this unit for the first use. Failure to correctly perform these steps can damage this unit and/or shorten its life. If still unsure about how to perform any of these steps after reading this section, call 1-866-460-9436 Monday - Friday, 8 AM - 4 PM Central Time for customer service.

If this unit is being used for the first time, the following few steps are required to prepare it for operation:

### Step 1 - Add Oil

**THIS UNIT REQUIRES AT LEAST 20 OUNCES OF OIL (SAE10W-30) TO RUN.**

**ADD OIL UNTIL IT IS ALMOST OVERFLOWING.** THE LOW-OIL SENSOR IS VERY SENSITIVE AND THE ENGINE WILL NOT RUN IF THE OIL IS LOW. **START WITH 20 OUNCES, THEN ADD MORE UNTIL ALMOST OVERFLOWING.**

**TROUBLESHOOTING:** IF THE UNIT WILL NOT START, DOUBLE CHECK THAT THE OIL LEVEL IS COMPLETELY FULL AND ALMOST OVERFLOWING.

**This unit requires engine oil to function. Engine oil is a major factor affecting engine performance and service life.** When new from the package, this unit contains no oil in the engine crankcase. Add oil before operating this unit for the first time. When replenishing oil for subsequent use of this unit, always determine that this unit has the correct quantity of oil.

To add oil to the engine crankcase:

1. Confirm that this unit is on a level surface.
2. Unscrew the oil filler/dipstick cap.
4. Using a funnel, add high detergent motor oil to fill the engine crankcase to the correct quantity. SAE10W-30 oil is recommended for general use.

When the engine crankcase is full, the oil level should reach the lower lip of the oil filling opening as shown in Figure 2.

5. Replace the oil filler/dipstick cap and reattach the oil access panel.



Figure 2 - Add Oil

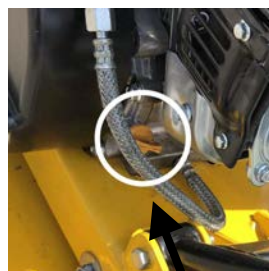

(Back Location) Adding oil

NOTE: While there are two locations to add oil, it is easier to use the Back location as indicated above.

NOTE: We recommend using conventional motor oil. However, you may choose to use synthetic. Either oil can be used, but the oils cannot be mixed and the same oil must be used throughout the life of the unit.

## Step 2 - Add Gasoline

### **⚠ WARNING**

**Gasoline and gasoline fumes are highly flammable and explosive. Handling fuel can result in serious injury or burns.**

- Do not fill the fuel tank near a heat, sparks or an open flame. Keep gas away from pilot lights, barbecues, electric appliances, power tools, etc.
- Do not overfill the fuel tank. Check for fuel spills and immediately wipe them up. Spilled fuel is a fire hazard and causes environmental damage.

#### **To add gasoline:**

To ensure that this unit runs smoothly, use only FRESH, UNLEADED GASOLINE WITH AN OCTANE RATING OF 87 OR HIGHER. Unleaded gasoline produces fewer engine and spark plug deposits and extends the life of the exhaust system.

1. Confirm that this unit is on a level surface.
2. Unscrew fuel tank cap and set aside. (NOTE: The fuel tank cap may be tight and difficult to unscrew.)
3. Slowly add fresh, unleaded gasoline (with an octane rating 87 or higher) to the fuel tank. Be careful not to fill the fuel tank above the upper limit line. NOTE: Because gasoline can expand, do not fill the fuel tank to the very top.
4. Securely tighten the fuel tank cap and immediately wipe up any spilled gasoline with a dry cloth.

<b>Fuel Tank Capacity (gallons)</b>	1
<b>Fuel Type</b>	Fresh, Unleaded Gasoline Octane Rating 87 or Higher

#### **IMPORTANT:**

- Use only UNLEADED gasoline with an octane rating of 87 or higher.
- Never use a mixture of oil and gasoline.
- Never use old and/or contaminated gasoline.
- Avoid getting dirt and/or water in the fuel tank.
- Gasoline can age in the fuel tank and make it difficult to start this unit. Never store this unit for extended time with gasoline in the fuel tank.

### **⚠ WARNING**

**Gasoline and gasoline fumes are highly flammable and explosive. Handling fuel can result in serious injury or burns.**

- Do not fill the fuel tank near a heat, sparks or an open flame. Keep gasoline away from appliance pilot lights, barbecues, electric appliances, power tools, etc.
- Always allow several minutes for the engine to cool before refueling.
- Do not overfill the fuel tank. Always check for fuel spills and immediately wipe them up. Spilled fuel is a fire hazard and causes environmental damage.

## STARTING THE UNIT

# STOP!

Before starting this unit, confirm that all the steps in the section titled, "Preparing the Unit for Use," of this manual have been correctly completed. If unsure about how to perform any of these steps, call 1-866-460-9436, Monday - Friday, 8 AM - 4 PM Central Time for customer service.

### **⚠ CAUTION**

**Disconnect all electrical loads from this unit before attempting to start.**

To start this unit:

- Turn engine On/Off switch to "ON".
- If the engine is cold, move the choke lever to the "close" position. If the engine is hot, set the choke lever to the "open" position.
- Pull the starter grip gently until resistance is felt, then pull hard.
- Leave the engine run idle for 5 minutes for warm-up.

1. Once the engine has started, firmly grasp the compactor's handle bar with one hand then quickly turn the throttle lever to high speed.

**Note:** Always move the throttle lever quickly without hesitation, because increasing the engine speed slowly will cause the clutch to slip.

2. Firmly grasp the compactor's handle bar with both hands as the compactor begins to move forward.

3. Walk behind the compactor watching for any large objects or foreign matter that might cause damage to the compactor or shoot out causing bodily injury. If objects are in the travel path, slow the engine (stopping compactor travel) and remove the object before proceeding.

The compactor's travel speed may slow down on soils that contain clay, however there may be cases where the travel speed slows because the vibrator/compaction plate does not leave the ground surface easily due to the composition of the soil. To correct this problem:

- (With the compactor turned off) check the vibrator plate to see if clay or other material has been lodged in the mechanism. If so, clean the plate/mechanism with water and remove the material.
- Remember that the compactor does not work efficiently on clay or very moist soil.
- If the soil is very moist, dry it to a suitable level or perform compaction twice.

To stop this unit:

Never stop the engine abruptly from full speed. Slow the speed and allow the engine to run idle for a few minutes. This is necessary to prevent the moisture of the outside air from getting into the engine carburetor.

- Slow the engine to idle by turning accelerator lever fully counterclockwise.
- Shift the engine On/Off switch to the "OFF" position.
- Close the fuel valve.

## Operation

**Note:** Whenever high speed operation (over 3600 RPM) is NOT required, slow the engine by moving the speed control lever to a low position to save fuel and extend the life of the equipment.

1. Once the engine has started, firmly grasp the compactor's handle bar with one hand then quickly turn the throttle lever to high speed. The engine speed should be around 2,300 RPM and therefore engage the centrifugal clutch.

**Note:** Always move the throttle lever quickly without hesitation, because increasing the engine speed slowly will cause the clutch to slip.

2. Firmly grasp the compactor's handle bar with both hands as the compactor begins to move forward.

3. Walk behind the compactor watching for any large objects or foreign matter that might cause damage to the compactor or shoot out causing bodily injury. If objects are in the travel path, slow the engine (stopping compactor travel) and remove the object before proceeding.

The compactor's travel speed may slow down on soils that contain clay, however there may be cases where the travel speed slows because the vibrator/compaction plate does not leave the ground surface easily due to the composition of the soil. To correct this problem:

- (With the compactor turned off) check the vibrator plate to see if clay or other material has been lodged in the mechanism. If so, clean the plate/mechanism with water and remove the material.
- Remember that the compactor does not work efficiently on clay or very moist soil.
- If the soil is very moist, dry it to a suitable level or perform compaction twice.

## Changing The V-Belt

Check that the compactor engine is turned off and cool before attempting to change the V-belt. Changing the V-belt while the compactor is still operating may cause injury.

1. Loosen the four bolts (02) to remove the belt cover (01).
2. Remove the belt (03).
3. Prepare a new belt (item 17).
4. When fitting the belt, fit the smaller pulley (04) first, then the bigger pulley (05).
5. Once you change the belt, check whether the distance of A is 3/8" to 1/2" by pressing belt with finger (see bottom figure).
6. Reinstall the belt cover with the bolts and tighten the bolts.

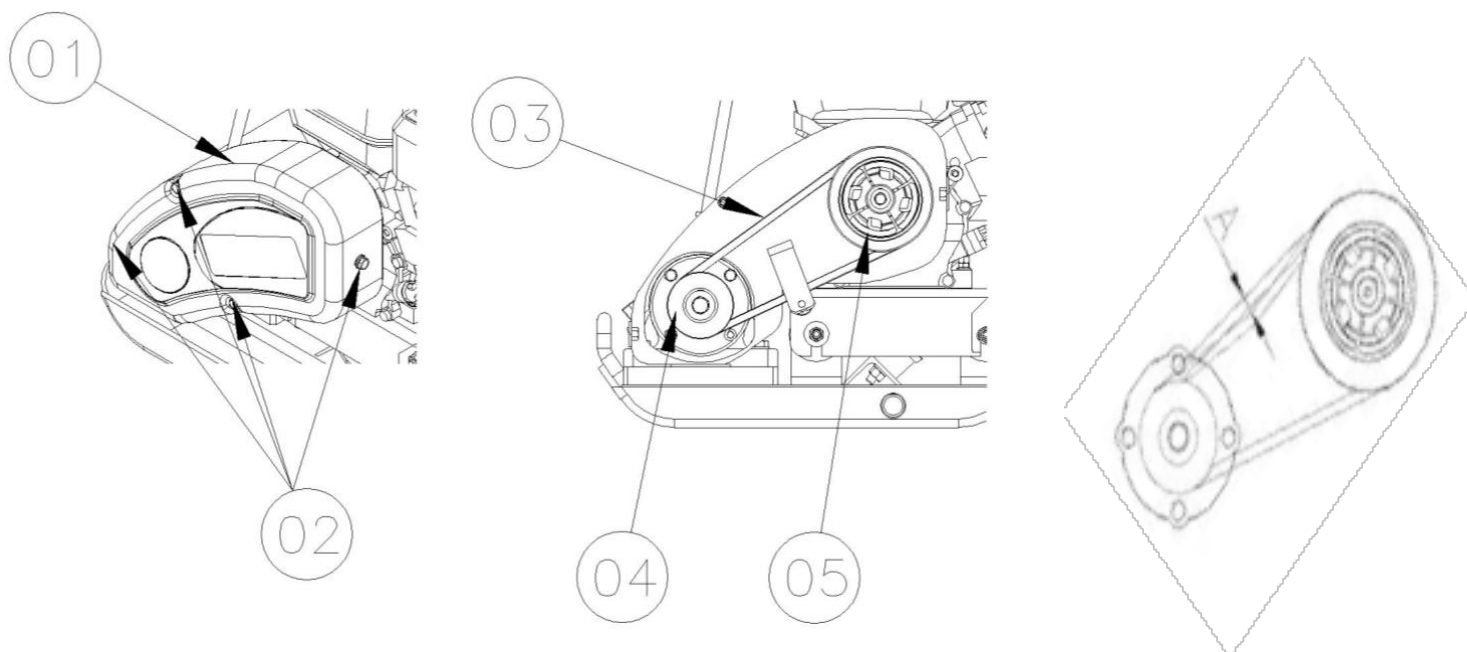

## Tensioning The V-Belt

Proper belt tension is critical to good performance. Proper adjustment will assure long belt life. Too much or too little belt tension will cause premature belt failure.

1. Loosen 4 engine mount bolts (do not remove) only enough to move the engine forward.
2. Loosen the jam nuts B, leaving enough space between the nut and bracket.
3. Push engine toward the back of the plate by turning the adjustment bolts A to remove any slack in V-belt(s).
4. When the V-belt tension is correct, tighten the jam nuts B against the bracket.
5. Tighten the engine mount bolts.
6. Replace the belt guard.



## STOPPING THE UNIT

To stop this unit:

1. Set the engine power switch to the "OFF" position.

### **⚠ WARNING**

Allow this unit to cool down before touching areas that become hot during operation.

### **⚠ CAUTION**

Allowing gasoline to sit in this unit's fuel tank for extended time without use can increase the difficulty in starting this unit in the future. Never store this unit for extended time with gasoline in the fuel tank.

## MAINTENANCE/CARE

Proper routine maintenance of this unit is essential for safe, economical, and trouble-free operation. It will help prolong the life of this unit as well as help reduce air pollution. Perform maintenance checks and procedures according to the schedule in Figure 7.

### **⚠ CAUTION**

Never perform maintenance procedures while this unit is running. Allow this unit to cool before commencing any maintenance procedures. Keep heat, sparks and flame away.

### **⚠ WARNING**

Improper maintenance and/or failure to correct any problems prior to operating this unit can cause a malfunction which could cause death or serious injury. Always follow the inspection and maintenance recommendations and schedules in this manual.

### Recommended Maintenance Schedule

		Each Use	Every Month or Each 20 Hrs	Every 3 Months or Each 50 Hrs	Every 6 Months or Each 100 Hrs	Every Year or Each 300 Hrs
Engine Oil	Check Level	X				
	Replace		X (first use)		X	
Air Filter	Check	X				
	Clean			X		
Spark Plug	Check/Clean				X	
Fuel Tank	Verify Gas Level	X				
	Clean					X

Figure 7 - Recommended maintenance schedule

### Cleaning the Unit

Always try to use this unit in a cool dry place. If this unit becomes dirty, the exterior can be cleaned with a damp cloth, soft brush, vacuum and/or pressurized air. Never clean this unit with a bucket of water and/or a hose as water can get inside and cause a short circuit or corrosion. Never use gasoline to clean parts of this unit.

### Replacing The V-Belt

1. Loose 4 engine mount bolts (do not remove) only enough to move the engine forward.
2. Loosen the jam nuts B and bolts A shown in above figure.
3. Slide the engine toward the front of plate and slip the old V-belt(s) off of the wheel pulley and install the new V-belt(s) in their place.
4. Position the V-belt(s) over the engine pulley.
5. Move the engine back.
6. When the V-belt tension is correct, tighten the jam nuts B and the engine mount bolts.
7. Replace the belt guard

## Lubrication / Automatic Transmission Fluid

The housing is pre-serviced using Automatic Transmission Fluid Dextron III, Mercon, EXXON (ESSO) NUTO H-32 or its equivalent. Change fluid after 200 hours of operation.

1. Let exciter cool before changing exciter oil.

2. Remove the belt guard and V-belt(s).

3. Remove the bolts that hold the deck to the housing.

4. Lift entire deck with engine from housing.

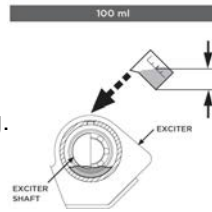

5. Remove pipe plug from top of exciter housing. Tilt housing upside down so oil drains from exciter. Examine oil for metal chips as a precaution to future problems.

6. Return plate housing to the upright position

7. Fill the exciter housing with exciter oil.

8. Apply pipe sealant to pipe plug and reinstall into top of exciter housing.

9. Reinstall deck, V-belt(s) and belt guard.

## Checking the Oil Level

It is important to check the oil level in the engine crankcase before each use to ensure that there is a sufficient quantity.

To check the oil level:

1. Verify that this unit is shut down and on a level surface.

2. Unscrew the oil filler/dipstick cap from the engine.

3. With a dry cloth, wipe the oil off of the dipstick that is located on the inside of the cap.

4. Insert the dipstick as if replacing the cap and then remove again. There should be oil on the dipstick. If there is no oil on the dipstick, or oil is visible only at the very end of the dipstick, add oil until the engine crankcase is filled.

5. Confirm that the oil filler/dipstick cap is properly in place when finished verifying the oil level.

## Draining Oil

The oil should be changed after the first 20 hours of operation. Subsequently, the oil should be changed every 6 months, or for every 100 hours of use, or when the oil has become contaminated with water and/or dirt.

To drain the oil from this unit:

1. Place a bucket to the side of this unit to catch oil as it drains.

2. Unscrew the oil drain plug located on the crankcase underneath the oil filler/dipstick cap using 12 mm hex wrench.

3. Allow all the oil to drain from this unit.

4. Replace the oil drain plug and tighten using 12 mm hex wrench.

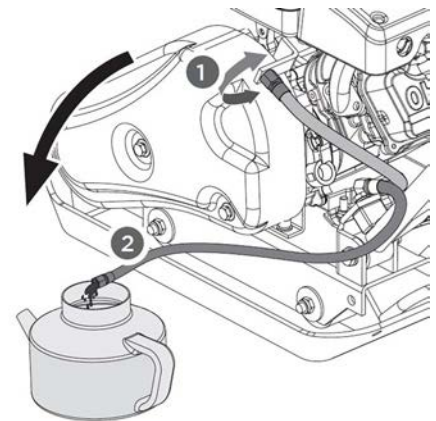

(Back Location) Draining oil

**NOTE: Never dispose of used motor oil in the trash, down a drain or on the ground. Put oil in a sealed container and contact your local recycling center or auto garage to arrange oil disposal.**

## Adding Oil

To add oil to the engine crankcase:

1. Confirm that this unit is on a level surface.
2. Unscrew the oil filler/dipstick cap.
4. Using a funnel, add high detergent motor oil to fill the engine crankcase to the correct quantity. SAE10W-30 oil is recommended for general use. When the engine crankcase is full and almost overflowing, the oil level should reach the lower lip of the oil filling opening as shown in Figure 2.
5. Replace the oil filler/dipstick cap and reattach the oil access panel.



Figure 2 - Add Oil

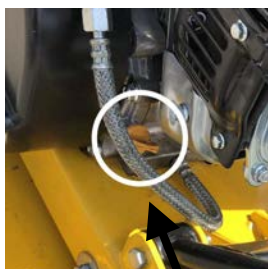

(Back Location) Adding oil

NOTE: While there are two locations to add oil, it is easier to use the Back location as indicated above.

NOTE: We recommend using conventional motor oil. However, you may choose to use synthetic. Either oil can be used, but the oils cannot be mixed and the same oil must be used throughout the life of the unit.

## Air Filter Maintenance

Routine maintenance of the air filter helps maintain proper airflow to the carburetor. Occasionally verify that the air filter is free of excessive dirt. The air filter will require more frequent cleaning when operating this unit in extremely dusty areas.

To clean the air filter, remove the foam filter element from the unit and wash it in warm water and household dish detergent. Thoroughly rinse and dry. Pour a small amount of motor oil onto the filter, ring out ALL excess oil, and reinstall the foam filter element in the unit.

Unscrew the bolts, or unsnap the clips at the top and bottom of the air filter cover, located below the choke lever, to access the foam filter element.

## Spark Plug Maintenance

The spark plug is essential for proper engine operation. The spark plug should be intact, free of deposits, and properly gapped. A bad or incorrectly installed spark plug can cause engine damage. To inspect the spark plug:

1. Remove the spark plug by pulling on the spark plug cap.
2. Unscrew the spark plug from this unit by using the included spark plug wrench.
3. Visually inspect the spark plug. If it is cracked and/or chipped, discard and install a new spark plug. A F7TC spark plug is recommended.
4. Measure the spark plug electrode gap with a gauge. The gap should be 0.020-0.028in (0.5-0.7mm). (See Figure 9.)
5. If re-using the spark plug, use a wire brush to clean any dirt from around the spark plug base and then re-gap the spark plug.
6. Screw the spark plug back into place on this unit by using the included spark plug wrench.
7. Replace the spark plug cap.

Figure 9  
Measuring the spark plug gap

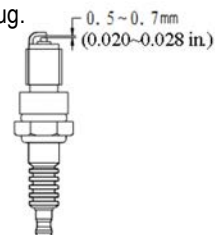

## To store this unit for extended time, drain the gasoline from the carburetor AND fuel tank.

To drain gasoline from this unit:

1. Turn the fuel valve to the "off" position and let the engine run until it stops.
2. Remove the fuel filter cup.
3. Empty the fuel filter cup of any fuel.
4. Place a receptacle underneath this unit to catch gasoline as it drains.
5. Turn the fuel valve to the "on" position and allow all gasoline to drain.
6. Turn the fuel valve to the "off" position.
7. Replace the fuel filter cup.
8. Store the drained gasoline in a suitable place.

To store this unit for extended time, the fuel needs to be drained from the carburetor. To drain the gasoline from the carburetor turn the fuel valve to the "off" position while the engine is running. The unit will shut down when all the gasoline in the carburetor has been used.

## Lubrication Maintenance

Change fluid after 200 hours of operation.

1. Let exciter cool before changing exciter oil.
2. Remove the belt guard and V-belt(s).
3. Remove the bolts that hold the deck to the housing.
4. Lift entire deck with engine from housing.
5. Remove pipe plug from top of exciter housing. Tilt housing upside down so oil drains from exciter. Examine oil for metal chips as a precaution to future problems.
6. Return plate housing to the upright position.
7. Fill the exciter housing with exciter oil.  
*Do not overfill - overfilling can result in excessive temperatures in the exciter.*
8. Apply pipe sealant to pipe plug and reinstall into top of exciter housing.
9. Reinstall deck, V-belt(s) and belt guard.

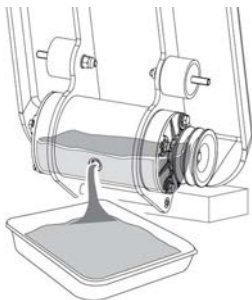
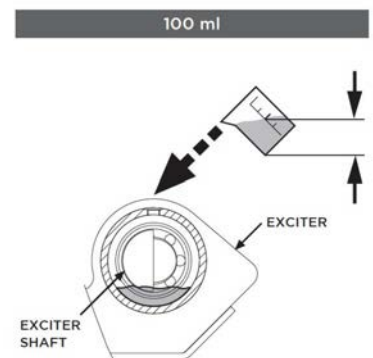
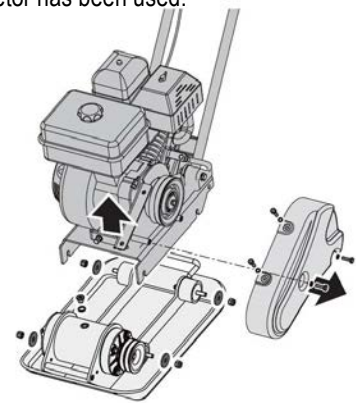

## STORAGE/TRANSPORT PROCEDURES

### **CAUTION**

Do not store gasoline in unit for more than 3 months.

### **CAUTION**

Never place any type of storage cover on this unit while it is still hot.

When transporting or storing this unit for extended time:

- Allow unit to fully cool before moving it. A hot engine and exhaust system can burn you and ignite some materials.
- Empty the fuel tank. (See “Emptying the Fuel Tank” in the “Maintenance/Care” section.)
- Turn the fuel valve to the “off” position.
- Disconnect the spark plug.
- Do not obstruct any ventilation openings.
- Do not drop or strike this unit while moving it.
- Store this unit in a cool dry area, free of excessive dust.

Storage Time	Recommended Storage Procedure (which will help prevent difficult starts)
Less than 1 month	No storage procedure required.
1 to 2 months	Fill with fresh gasoline and add gasoline conditioner
2 months to 1 year	Empty the fuel tank. (See “Emptying the Fuel Tank” in the “Maintenance/Care” section.)
1 year or more	Empty the fuel tank. (See “Emptying the Fuel Tank” in the “Maintenance/Care” section.) Disconnect the spark plug.

### Lifting /Transporting

Carefully fold the upper handle down. Do not allow control cables to become pinched or bent. Store your plate compactor in upright position in a clean, dry building that has good ventilation

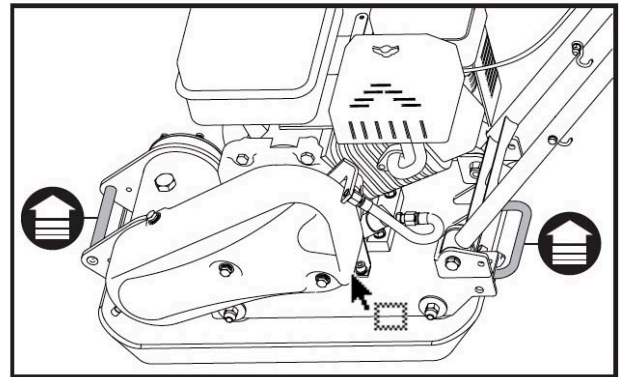
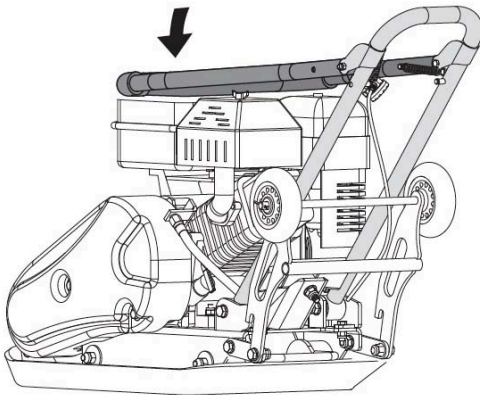

## TROUBLESHOOTING

**IMPORTANT:** If trouble persists, call our customer help line at 1-866-460-9436, Monday - Friday, 8 AM - 4 PM Central Time.

Symptom	Cause	Solution
Engine will not start.	Engine switch is set to "off."	Set engine switch to "on."
	Fuel valve is turned to "closed."	Turn fuel valve to "open."
	Choke is set to "Open/Run".	Set the choke to "Closed/Choke"
	Engine is out of gasoline.	Add gasoline.
	Engine is filled with contaminated and/or old gasoline.	Drain gasoline from the engine and add new gasoline.
	Spark plug is dirty.	Clean spark plug.
	Spark plug boot is cracked.	Replace spark plug.
	Spark plug is broken.	Replace spark plug.
	Oil is low.	The oil level should almost OVERFLOW. If it is not, add more oil.
Engine will not start.	Spark plugs not sparking.	Verify that you have spark. Pull spark plug cap off spark plug. Take spark plug out using spark plug wrench. Put spark plug back into boot and hold it onto bare metal. Make sure the on/off switch is in the ON position. Pull the starter. You should see a spark.
Engine will not start.	Carburetor is gummed up.	If the unit has been sitting for a long time, it is possible that it is gummed up. Remove air box cover, then remove the air filter. Remove the two 10mm nuts that hold the carburetor. Lift up on the throttle linkage on the top of the carburetor. It should pop off. Pull the fuel line off. The carburetor will slide off. Turn the carburetor upside down and remove the 10mm bolt on the bottom of the bowl. Remove the pin that holds the float on. Pull the float up. Inspect the float needle, and make sure the orifice is not gummed up. Remove the rubber gasket, then clean the orifice if it is dirty. Use carb cleaner. Do not spray carb cleaner on the float needle or any rubber.
Engine will not start.	Gas is not getting to carburetor.	Make sure gas is getting to the carburetor. Remove the carburetor and turn the drain screw counter clockwise. Don't remove completely.
Engine will not start.	Two wires on the back of the switch may be disconnected.	Make sure two wires on the back of the switch are connected.
Unit starts but won't stay running	Choke is in "Closed/Choke" position, or gas is empty.	Make sure that after it is started, move the Choke to the "Open/Run" position. Make sure at least one inch of gas is in the tank.

# PARTS DIAGRAM

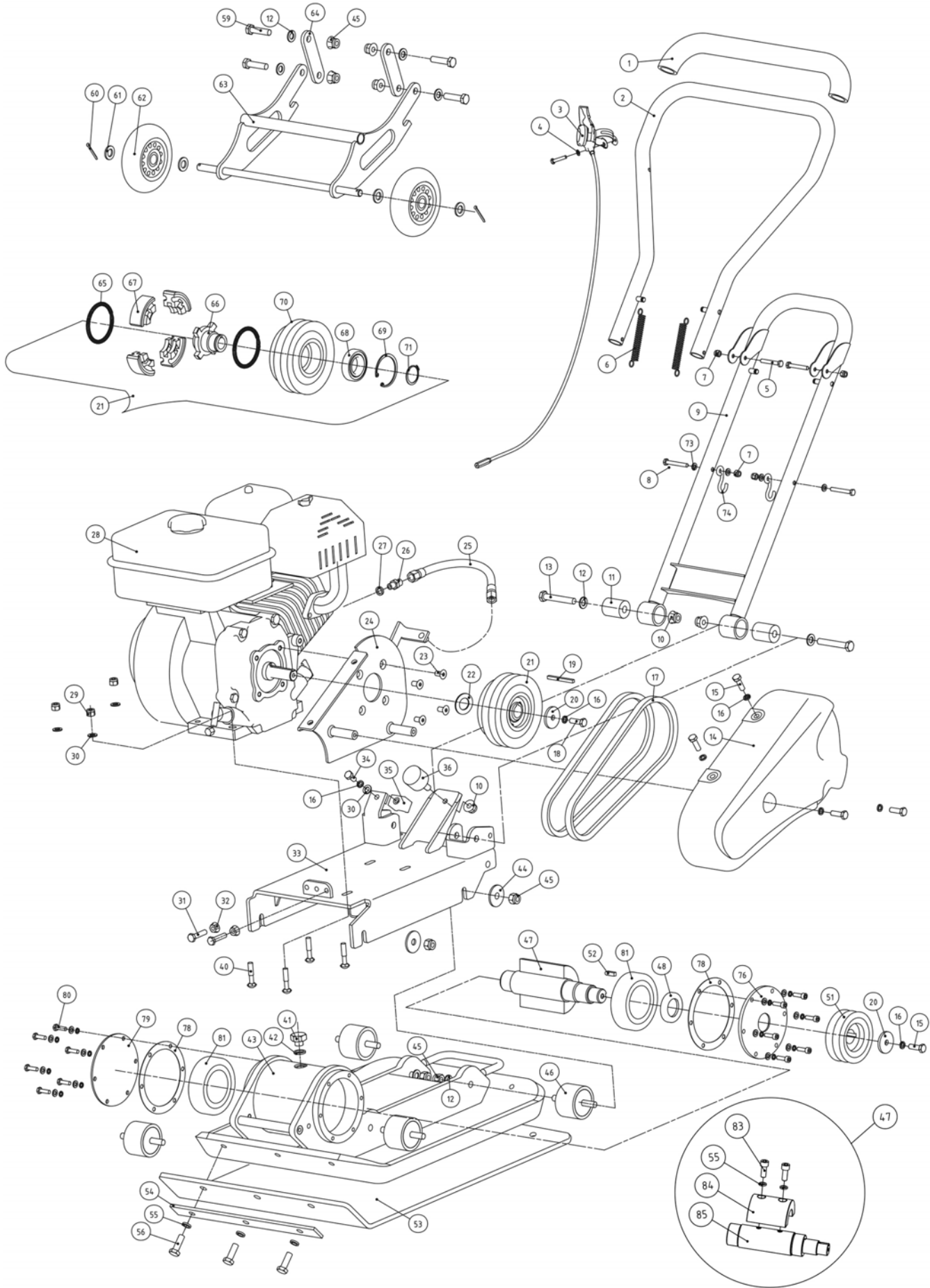

## PARTS LIST

ITEM	#	Description	Qty	
1	5030352	Handle Grip	1	
2	8051299	Upper Handle	1	
3	5010369	Throttle Control Switch with Cable	1	
4	2040001	Flat Washer 5	1	
5	2010062	Bolt M6x50	2	
6	5030353	Spring	2	
7	2030008	Lock Nut M6	4	
8	2010060	Bolt M6x40	2	
9		Lower Handle	1	
10	2030076	Lock Nut M10	3	
11	5030339	Rubber Sleeve	2	
12	2040004	Flat Washer 10	10	
13	2010027	Bolt M10x65	2	
14	5030272	Belt Cover	1	
15	2010067	Bolt M8x20	5	
16	2040011	Lock Washer 8	7	
17	2080069	Belt A725	2	
18	2010068	Bolt M8x25	1	
19	2050087	Key 5x5x35	1	
20	5050747	Washer	2	
21	8071161	Centrifugal Clutch	1	
22	5050882	Washer	1	
23	2020198	Bolt M8x16	4	
24		Belt Cover Mount Bracket	1	
25				
26	5010356	Hose	1	
27				
28		Engine	1	
29	2030009	Lock Nut M8	4	
30	2040003	Flat Washer 8	5	
31	2010073	Bolt M8x45	2	
32	2030027	Flange Nut M8	2	
33		Engine Deck	1	



34	2010066	Bolt M8x16	1	
35	5030265	Stop Block	1	
36	5030266	Shock Absorber	1	
37				
38				
39				
40	2010205	Bolt M8x45	4	
41	8020986	Plug	1	
42	2040048	Washer Groupware 14	1	
43		Base Plate	1	
44	5050790	Washer 38x11x3	4	
45	2030010	Lock Nut M10	12	
46	5030264	Shock Absorber	4	
47		Shaft	1	
48	2070086	Seal FB30x42x6	1	
49				
50				
51	8050771	Pulley	1	
52	2050134	Key B6x18	1	
53	5030273	Paving Pad	1	
54		Clamp Plate	1	
55	2040012	Lock Washer 10	5	
56	2010079	Bolt M10x25	3	
57				
58				
59		Bolt M10x30	4	
60	2050135	Pin 2.5x25	2	
61	2040005	Flat Washer 12	4	
62	5030269	Wheel	2	
63		Wheel Bracket	1	
64		Line Plate	1	
65	5010352	Spring	2	
66	5050788	Hub	1	
67	5010469	Clutch Lining	4	
68	2060111	Ball Bearing 6006-2RS	1	

69	2040070	Snap Ring 55	1	
70	8050756	Clutch Pulley	1	
71	2040090	Snap Ring 30	1	
72				
73	2040002	Flat Washer 6	6	
74	5050917	Wheel Kit hook	2	
75				
76	8050770	Bearing Cover Left	1	
77				
78	5060037	House Gasket	2	
79	8050769	Bearing Cover Right	1	
80		Bolt M6x20	12	
81	2060120	Ball Bearing 6309	2	
82				
83	2020173	Bolt M10x25	2	
84	5050803	Off-center Iron	1	
85	5050802	Shaft	1	

# ENGINE DIAGRAM

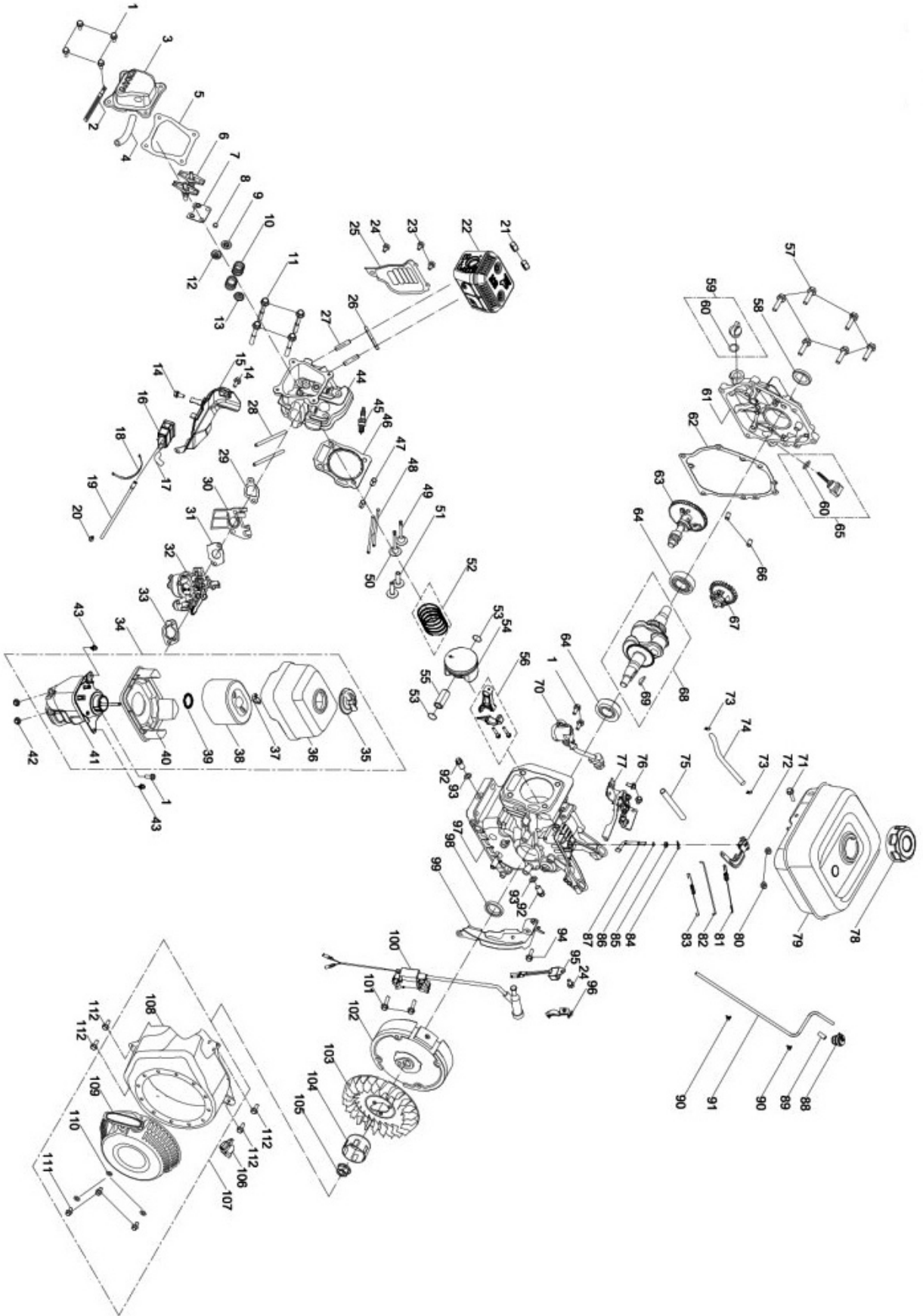

## ENGINE PARTS LIST

NO	Part No	Description	Qty
1	100011264	Bolt, M6×16	7
2	100000655	Clip	1
3	100056645	Valve Cover	1
4	100002829	Breather Hose	1
5	100010181	Gasket, Valve Cover	1
6	100004420	Rocker Arm Assembly	2
7	100050881	Rocker Arm Base	1
8	100004588	Valve Adjust Cap, Exhaust	1
9	100004585	Valve Spring Seat	1
10	100004564	Valve Spring	2
11	100002463	Bolt, M8×65	4
12	100004580	Valve Spring Seat	1
13	100004600	Intake Valve Seal	1
14	100011260	Bolt, M6×10	2
15	100071973	Shroud	1
16	100008951	Carbon Canister	1
17	100081431	Fuel Hose	1
18	100000568	Tape, L=150mm	1
19	100081432	Fuel Hose	1
20	100062810	Clamp	1
21	100011422	Nut, M8	2
22	100006319	Muffler	1
23	100011248	Bolt, M5×10	2
24	100011261	Bolt, M6×12	2
25	100006608	Exhaust Pipe Guard	1
26	100006526	Gasket, Muffler	1
27	100010387	Stud, M8×34	2
28	100010359	Stud, M6×110	2
29	100005559	Gasket, Carburetor Insulator	1
30	100005599	Insulator	1
31	100005922	Gasket, Carburetor	1
32	100005290	Carburetor	1
33	100005629	Gasket, Carburetor	1
34	100062488	Air Filter Assembly	1
35	100023676	Air Filter Cover	1
36	100023669	Air Filter Cover	1
37	100005079	Butterfly Nut	1
38	100023670	Air Filter Element	1
39	100023666	Gasket, Air Filter	1
40	100023674	Air Filter Lower Cover	1
41	100064434	Air Filter Base Assembly	1
42	100011463	Nut, M6	2
43	100000672	Clip	2
44	100002378	Cylinder Head	1
45	100009376	Spark Plug	1
46	100063767	Gasket, Cylinder Head	1
47	100010558	Pin, φ10×16	2
48	100004395	Push Rod	2
49	100057969	Exhaust Valve	1
50	100004522	Intake Valve	1
51	100004262	Tappet	2

NO	Part No	Description	Qty
52	100003238	Piston Ring Set	1
53	100003221	Circlip	2
54	100003074	Piston	1
55	100003123	Piston Pin	1
56	100003446	Connecting Rod Assembly	1
57	100011319	Bolt, M8×32	6
58	100017651	Oil Seal, φ25×φ41.25×6	1
59	100004171	Oil Plug	1
60	100010077	O-Ring, φ15.8×2.5	2
61	100002975	Crankcase Cover	1
62	100010148	Gasket, Crankcase	1
63	100004293	Camshaft	1
64	100010680	Bearing, 6205	2
65	100004105	Dipstick	1
66	100010550	Pin, φ8×14	2
67	100050820	Governor Gear	1
68	100003691	Crankshaft	1
69	100010577	Woodruff Key	1
70	100010011	Oil Sensor	1
71	100011269	Bolt, M6×28	1
72	100039298	Governor Lever	1
73	100005137	Clamp	2
74	100063788	Fuel Hose, φ4×φ8×155	1
75	100009151	Fuel Hose Jacket	1
76	100011215	Bolt, M6×12	2
77	100008100	Governor Gear Bracket Assembly	1
78	100062486	Fuel Cap	1
79	100066775	Fuel Tank	1
80	100011452	Nut, M6	2
81	100007855	Governor Spring	1
82	100007947	Throttle Linkage	1
83	100030049	Idle Spring	1
84	100007986	Cotter Pin	1
85	100017630	Oil Seal, φ6×φ11×4	1
86	100010113	O-Ring, φ5.2×1.9	1
87	100007976	Governor Gear Shaft	1
88	100008968	Roll Over Valve	1
89	100063948	Fuel Hose Jacket	1
90	100005148	Clamp	2
91	100081574	Fuel Hose	1
92	100010272	Earth Bolt	2
93	100010459	Washer, φ10×1.5×φ16	2
94	100011266	Bolt, M6×20	1
95	100010040	Oil Sensor	1
96	100068191	Clip	1
97	100002641	Crankcase	1
98	100017644	Oil Seal, φ25×φ41.25×6	1
99	100007053	Lower Shield	1
100	100009240	Ignition Module	1
101	100011268	Bolt, M6×25	2
102	100009503	Flywheel	1
103	100007028	Cooling Fan	1

NO	Part No	Description	Qty
104	100007550	Starter Cup	1
105	100011459	Nut, M14×1.5	1
106	100009166	Stop Switch	1
107	100023738	Recoil Starter	1
108	100031174	Blower Housing	1
109	100023743	Recoil Starter	1
110	100010894	Washer, φ6	3
111	100011565	Bolt, M6×10	3
112	100011262	Bolt, M6×14	4

# FEDERAL and CALIFORNIA EXHAUST AND EVAPORATIVE EMISSIONS CONTROL WARRANTY STATEMENT

## YOUR WARRANTY RIGHTS AND OBLIGATIONS

The United States Environmental Protection Agency (EPA), the California Air Resources Board, and Buffalo Corp are pleased to explain the exhaust and evaporative emissions (“missions”) control system’s warranty on your 2019 small off-road engine or equipment (SORE). In California, new equipment that use small off-road engines must be designed, built, and equipped to meet the State’s stringent anti-smog standards. Buffalo Corp must warrant the emissions control system on your SORE for the periods of time listed below provided there has been no abuse, neglect or improper maintenance of your small off-road engine or equipment leading to the failure of the emissions control system.

Your emissions control system may include parts such as the carburetor or fuel-injection system, the ignition system, catalytic converter, fuel tanks, fuel lines (for liquid fuel and fuel vapors), fuel caps, valves, canisters, filters, clamps and other associated components. Also included may be hoses, belts, connectors, and other emission-related assemblies.

Where a warrantable condition exists, Buffalo Corp will repair your SORE at no cost to you including diagnosis, parts and labor.

### MANUFACTURER’S WARRANTY COVERAGE:

This exhaust and evaporative emissions control system on your SORE is warranted for two years. If any emissions-related part on your SORE is defective the part will be repaired or replaced by Buffalo Corp.

### OWNER’S WARRANTY RESPONSIBILITIES:

As the SORE owner, you are responsible for performance of the required maintenance listed in your owner’s manual. Buffalo Corp recommends that you retain all receipts covering maintenance on your SORE, but Buffalo Corp cannot deny warranty coverage solely for the lack of receipts or for your failure to ensure the performance of all scheduled maintenance.

As the SORE owner, you should however be aware that Buffalo Corp may deny your warranty coverage if your SORE or a part has failed due to abuse neglect, or improper maintenance or unapproved modifications.

You are responsible for presenting your SORE to a Buffalo Corp distribution center or service center as soon as the problem exists. The warranty repairs shall be completed in a reasonable amount of time, not to exceed 30 days.

If you have any questions regarding your warranty rights and responsibilities, you should contact Buffalo Corp customer service representative at 1-866-460-9436 or email to [info@buffalotools.com](mailto:info@buffalotools.com).

### DEFECTS WARRANTY REQUIREMENTS:

**(a) Applicability.** This section applies to emissions control systems on small off-road engines or equipment that use small off-road engines subject to the emission standards in this Article. The warranty period begins on the date the engine or equipment is delivered to an ultimate purchaser

**(b) General Emissions Warranty Coverage.** The engine or equipment must be warranted to the ultimate purchaser and any subsequent owner that the emissions control system when installed was:

- (1) Designed, built, and equipped so as to conform with all applicable regulations; and
- (2) Free from defects in materials and workmanship that causes the failure of a warranted part for a period of two years..

**(c) The Warranty on emissions-related parts will be interpreted as follows:**

- (1) Any warranted part that is not scheduled for replacement as required maintenance in the written instructions furnished with each new engine or equipment must be warranted for the warranty period defined in subsection (b)(2). If any such part fails during the period of warranty coverage, it must be repaired or replaced by Buffalo Corp according to subsection (4) below.  
Any such part repaired or replaced under the warranty must be warranted for a time not less than the remaining warranty period.
- (2) Any warranted part that is scheduled only for regular inspection in the written instructions furnished with each new engine or equipment must be warranted for the warranty period defined in subsection (b)(2). A statement in such written instructions to the effect of "repair or replace as necessary" shall advise owners of the warranty coverage for emissions related parts. Replacement within the warranty period is covered by the warranty and will not reduce the period warranty coverage. Any such part repaired or replaced under warranty must be warranted for a time not less than the remaining warranty period..
- (3) Any warranted part that is scheduled for replacement as required maintenance in the written instructions furnished with each new engine or equipment must be warranted for the period of time prior to the first scheduled replacement point for that part. If the part fails prior to the first scheduled replacement, the part must be repaired or replaced by the manufacturer according to subsection (4) below. Any such part repaired or replaced under warranty must be warranted for a time not less than the remainder of the period prior to the first scheduled replacement point for the part.
- (4) Repair or replacement of any warranted part under the warranty provisions of this article must be performed at no charge to the owner at warranty station.
- (5) Notwithstanding the provisions of subsection (4) above, warranty services or repairs must be provided at distribution centers that are franchised to service the subject engines or equipment.
- (6) The owner must not be charged for diagnostic labor that leads to the determination that a warranted part is in fact defective, provided that such diagnostic work is performed at a warranty station.
- (7) Throughout emissions control system's warranty period set out in subsection (b)(2), Buffalo Corp must maintain a supply of warranted parts sufficient to meet the expected demand for such parts and must obtain additional parts if that supply is exhausted.
- (8) Manufacturer-approved replacement parts that do not increase the exhaust or evaporative emissions of the engine or evaporative emissions system must be used in the performance of any warranty maintenance or repairs and must be provided without charge to the owner. Such use will not reduce the warranty obligations of Buffalo Corp.
- (9) The use of add-on or modified parts may be grounds for disallowing a warranty claim made in accordance with this Article. Buffalo Corp will not be liable under this Article to warrant failures of warranted parts caused by the use of an add-on or modified part.
- (10) Buffalo Corp shall provide any documents that describe Buffalo Corp's warranty procedures or policies within five working days of request by the Executive Officer.

(d) A list of all emissions warranty parts must be included with each new engine or equipment subject to this Article. The emissions warranty parts list shall include all parts whose failure would increase exhaust or evaporative emissions, and contains the following parts (if applicable):

- (1) Fuel Metering System
  - Carburetor and internal parts (and/or pressure regulator of fuel injection system).
  - Air/fuel ratio feedback and control system.
  - Cold start enrichment system..
- (2) Air Induction System
  - Controlled hot air intake system.
  - Intake manifold.
  - Air filter.
- (3) Ignition System
  - Spark Plugs.
  - Magneto or electronic ignition system..

- Spark advance/retard system.
- (4) Exhaust Gas Recirculation (EGR) System
- EGR valve body, and carburetor spacer if applicable.
  - EGR rate feedback and control system.
- (5) Air injection System
- Air pump or pulse valve..
  - Valves affecting distribution of flow.
  - Distribution manifold
- (6) Catalyst or Thermal Reactor System
- Catalytic converter..
  - Thermal reactor..
  - Exhaust manifold.
- (7) Particulate Controls
- Traps, filter, precipitators, and any other device used to capture particulate emissions.
- (8) Miscellaneous items Used in Above Systems
- Vacuum, temperature, and time sensitive valves and switches.
  - Electronic controls.
  - Hoses, belts, connectors, and assemblies.
- (9) Evaporative Controls
- Fuel Tank
  - Fuel Cap
  - Fuel Lines (for liquid fuel and fuel vapors)
  - Fuel Line Fittings
  - Clamps\*\*
  - Pressure Relief Valves\*\*
  - Control Valves\*\*
  - Control Solenoids\*\*
  - Electronic Controls\*\*
  - Vacuum Control Diaphragms\*\*
  - Control Cables\*\*
  - Control Linkages\*\*
  - Purge Valves
  - Gaskets
  - Liquid/Vapor Separator
  - Carbon Canister
  - Canister Mounting Brackets
  - Carburetor Purge Port Connector

\*\*Note: As they relate to the evaporative emission control system.

**Note: Any other warranty statements apply to engines or equipment units shall not limit the emissions warranty period (two years) or its applicability to subsequent owners after the ultimate purchaser.**